

TEAC®

12

SERVICE MANUAL

A-450

Stereo Cassette Deck with Dolby* System

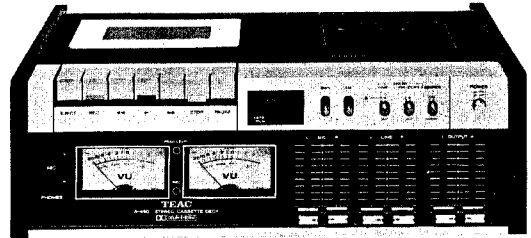

GENERAL INTRODUCTION

This Service Manual is provided to assist service technicians throughout the world to properly adjust, repair and maintain the TEAC A-450 Stereo Cassette Deck. The A-450 is designed to be used with a high quality stereo amplifier system. It contains many of the standard TEAC features such as selectable BIAS and EQ, DIN, MIC, LINE Inputs, PAUSE Control, Auto-End-Stop, PEAK LEVEL Indicator, Large VU Meters, TAPE RUN Indicator, etc. In addition it has Dolby NR Circuitry, DOLBY FM/COPY Facility, FM MPX Filter, MIC/LINE Mixing, Outer-rotor Motor and unexcelled Wow and Flutter Specs.

If adjustments or repairs are too complicated and are difficult for you to accomplish, or if you have any technical questions, please contact the nearest TEAC Factory Service Department or write directly to a TEAC office, the addresses of which are written on the back cover.

This manual is written specifically for the A-450 Model distributed in the U.S.A. and Canada. However, the differences in models distributed elsewhere is very small. See the chart on page 30 for a comparison of the various models.

NOTE

When ordering replacement parts, please refer to the PARTS LIST which is printed separately from this manual.

* Noise reduction circuit made under license from Dolby Laboratories Inc. The word "Dolby" and the Double-D symbol are trademarks of Dolby Laboratories Inc.

TEAC CORPORATION

51031682

12

CONTENTS

1.	Specifications & Service Data	3	7-1-1.	Record/Playback Head Azimuth Adjustments	17
2.	Test Equipment Required	4	7-1-2.	Specified Output Level Setting	17
	TEAC Test Tape	4	7-1-3.	VU Meter Calibration -Playback-	18
3.	Partial Dis-assembly of Main Parts	5	7-1-4.	Frequency Response -Playback-	18
3-1.	Case/Front Panel	6	7-1-5.	Signal to Noise Ratio -Playback-	18
3-2.	Motor	6	7-1-6.	Headphone Output Level Checks	19
3-3.	Cassette Holder	7	7-2.	Monitor Performance	19
3-4.	Head/Pinch Roller	7	7-2-1.	Minimum Input Level Checks	19
3-4A.	Head	7	7-2-2.	Specified LINE Control Setting	20
3-4B.	Pinch Roller	7	7-2-3.	DOLBY FM/COPY CAL Control Setting	20
3-5.	Brake Bracket	8	7-2-4.	VU Meter Calibration -Record-	20
3-6.	Capstan Drive Ass'y/Drive Belt	8	7-2-5.	LED Peak Level Indicator Calibration	20
3-7.	Reel Table	9	7-2-6.	Dolby NR Effect Measurement	21
3-8.	Fast Wind Roller Ass'y	10	7-2-7.	Dolby FM Compensator Efficiency Checks	21
3-9.	Power Transformer	10	7-3.	Recording Performance	22
3-10.	Play Idler Ass'y	11	7-3-1.	Bias Trap Adjustments	22
4.	Mechanical Checks and Adjustments	11	7-3-2.	Record Bias Setting	22
4-1.	Pinch Roller Pressure	11	7-3-3.	Record Level Setting	23
4-2.	Take-Up Torque	12	7-3-4.	Distortion Checks	23
4-3.	Fast Forward Torque	12	7-3-5.	Frequency Response -Overall-	24
4-4.	Rewind Torque	13	7-3-6.	Signal to Noise Ratio -Overall-	24
	Torque Measurement using The Cassette Torque Meter	13	7-3-7.	Erase Efficiency	25
4-5.	Brake Tension	13	7-3-8.	Channel Separation	26
4-6.	Tape Speed/Wow and Flutter	14	7-3-9.	Adjacent Track Crosstalk Measurement	26
4-6-1.	Tape Speed	14	7-4.	Adjustment Location	27
4-6-2.	Wow and Flutter	14	8.	Level Diagram	28
5.	Parts Location	15	9.	Trouble-Shooting	29
6.	Lubrication	16	10.	Model Differences Comparison Chart	30
6-1.	Motor	16	10-1.	Functional Difference Table	30
6-2.	Capstan Ass'y	16	10-2.	Electrical Alignment Section	30
6-3.	Flywheel Ass'y	16	10-3.	Frequency & Voltage Conversion	31
7.	Electrical Checks and Adjustments	16			
7-1.	Playback Performance	17			

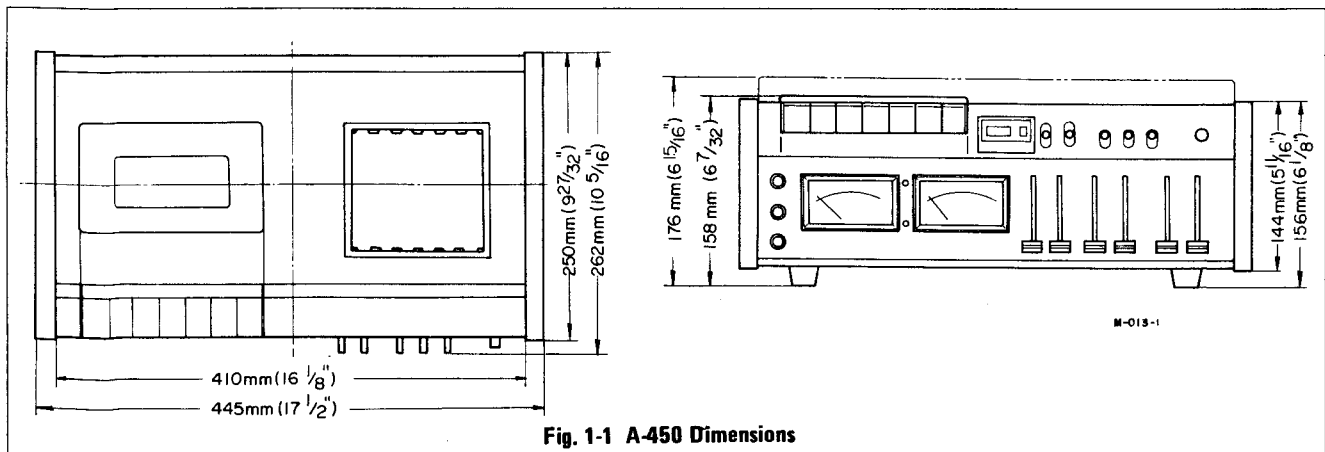

Fig. 1-1 A-450 Dimensions

1. SPECIFICATIONS & SERVICE DATA

SPECIFICATIONS

Track System	4-track, 2-channel stereo
Heads	Two: Erase and Record/Playback
Type of Tape	Cassette tape, C-60 and C-90 (Philips type)
Tape Speed	4.8 cm/s (1-7/8 ips)
Inputs (level and impedance)	Microphones: Min. input level: -67 dB \pm 2 dB (10 Kohms or more) Line: Specified input level: -5 dB (50 Kohms) Min. input level: -15 dB \pm 2 dB DIN*: Min. input level: -35 dB \pm 2 dB DOLBY FM/COPY: -15 dB \pm 2 dB
Outputs (level and impedance)	Line out: Max. output level: -3.5 dB \pm 1 dB (50 Kohms) Specified output level: -5 dB Headphones: Specified output level: -21 dB \pm 2 dB (8 ohms)
Equalization	EQ 1: 3180 μ s + 70 μ s (for CrO ₂ tape) EQ 2: 3180 μ s + 70 μ s (for FeCr tape) EQ 3: 3180 μ s + 120 μ s (for regular Hi-Fi tape)
Head Configuration	1/2-track, 1-channel Erase Head 1/4-track, 2-channel Record/Playback Head
Motor	Hysteresis synchronous outer-rotor motor
Bias Frequency	100 kHz
Operating Position	Horizontal
Power Requirements	117V AC, 60 Hz (U.S.A./Canada Models) 100/117/220/240V AC, 50/60 Hz (General Export Models) 220V AC, 50 Hz (Europe Models)
Power Consumption	18 W
Weight	9.5 kg (21 lbs) net

* Pursuant to DIN Standards

SERVICE DATA

Mechanical

Tape Speed Deviation	3,000 Hz \pm 30 Hz
Wow and Flutter	Playback: 0.07% (WRMS) Record/Playback: 0.10% (WRMS)
Pinch Roller Pressure	400 g \pm 20 g (13.5 ~ 15.0 oz)
Reel Torque	Take Up: 40 ~ 70 g·cm (0.6 ~ 1.0 oz·inch) Fast Forward: 100 g·cm (1.4 oz·inch) or more Rewind: 100 g·cm (1.4 oz·inch) or more
Fast Winding Time	100 seconds for C-60
End-stop Activate Time	4 seconds \pm 2 sec.

Electrical

Frequency Response	Refer to frequency response limits charts on page 18 and 24.
Signal to Noise Ratio	Playback method: 47 dB minimum Record/Playback method: BIAS/EQ 1: 47 dB minimum BIAS/EQ 2, 3: 45 dB minimum With Dolby Noise Reduction used for recording and playback, S/N ratio is improved by 5 dB at 1 kHz and 10 dB at frequencies over 5 kHz.
Erase Efficiency	65 dB minimum
Channel Separation	30 dB minimum (at 1 kHz)
Crosstalk between Adjacent Tracks	40 dB minimum (at 125 Hz)
Total Harmonic Distortion	BIAS/EQ 1: 2.5% (maximum) BIAS/EQ 2: 2.5% (maximum) BIAS/EQ 3: 2.5% (maximum)

NOTE: ● Improvements may result in Specifications and Service Data changes.
● Value of "dB" in the Data refer to 0 dB = 0.775V, except where specified. If a Test Set or VTVM calibrated to 0 dB = 1V is to be used, appropriate compensation should be made.

2. TEST EQUIPMENT REQUIRED

1. **Spring scale:** For take-up torque check: 0 – 70 g (0 – 2.5 oz.)
For fast forward & rewind torque checks: 0 – 200 g (0 – 7.0 oz.)
2. **String:** Length: about 50 cm (20")
3. **Cassette Reel Adapter:** Diameter: 22 mm
* The tools above (1 – 3) are constructed as shown in Fig. 2-2.
4. **Cassette Torque Meter:** For take-up torque check: 0 – 100 g·cm (0 – 1.4 oz. inch)
For fast forward & rewind torque checks: 0 – 160 g·cm (0 – 2.2 oz. inch)
* Use of the Cassette Torque Meter instead of the spring scale, if you have one, is recommended for easier measuring. (See Fig. 4-6 on page 13)
* When ordering Cassette Torque Meter, allow for longer delivery time that is required for it.
5. **Spring scale:** For Pinch Roller pressure check: 0 – 1 kg (2.2 lbs)
6. **Wow/flutter meter:** MEGURO DENPA SOKKI K.K., Model MK-668A
7. **Frequency counter:** Digital type, capable of 10 Hz to 100 kHz indication.
8. **AF oscillator:** 10 Hz – 100 kHz
9. **AC VTVM:** 0.1 mV – 300 V
10. **Attenuator:** General Purpose
11. **Distortion analyzer:** Basic frequency 400 Hz/1 kHz
12. **Oscilloscope:** General Purpose
13. **Band-pass filter:** 1 kHz narrow band-pass type
14. **Test load resistor:** Non inductive type 8 ohm/1 W
15. **Plastic alignment tool:**
16. **Head demagnetizer:** TEAC E-1 or equivalent
17. **Cleaner:** TEAC TZ-261 Tape Recorder Cleaner kit or pure alcohol
18. **Oil:** TEAC TZ-255 Oil kit or equivalent

TEAC TEST TAPE

REMARKS: 0 dB = DIN Reference Level (333 Hz)

For tape speed & wow/flutter test

- MTT-111:** • For Playback method
• 3,000 Hz/–10 dB
- MTT-502:** • For Record/playback method (blank tape)

For playback performance alignment

- MTT-150:** • For Dolby level Calibration
• Dolby B-type tone (modulated 400 Hz tone), 200 nWb/m
- MTT-116K:** • For frequency response test for EQ 1 & 2 (CrO₂ & Fe-Cr)
• 3180 μs + 70 μs
• 315 Hz/–4 dB, 31.5 Hz – 14 kHz/–24 dB
- MTT116U:** • For frequency response test for EQ 3 (Hi-Fi tape)
• 3180 μs + 120 μs
• 315 Hz/–4 dB, 31.5 Hz – 14 kHz/–24 dB

For record performance alignment (blank tape)

- MTT-505TB:** For BIAS 1/EQ 1 (CrO₂)
- MTT-504T:** For BIAS 2/EQ 2 (Fe-Cr)
- MTT-501:** For BIAS 3/EQ 3 (Hi-Fi tape)

NOTE: The TEAC test tapes require longer delivery time.



Fig. 2-1 TEAC Test Tape

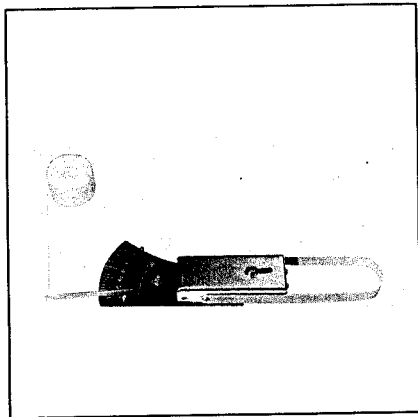

Fig. 2-2 Spring Scale & Cassette Reel Adapter

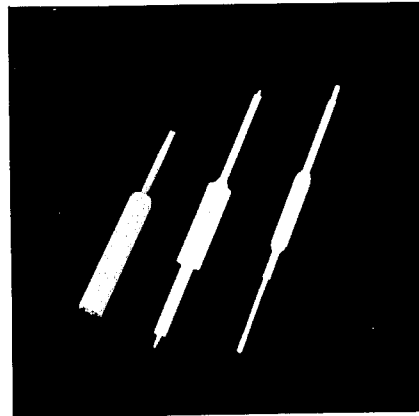

Fig. 2-3 Plastic Alignment Tool

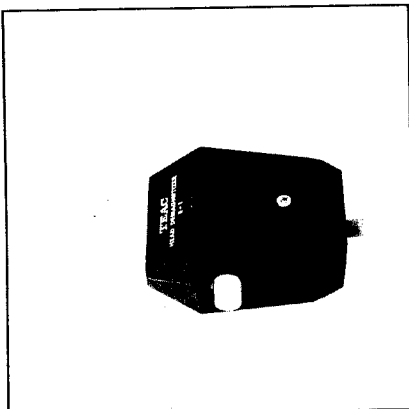

Fig. 2-4 E-1 Head Demagnetizer



Fig. 2-5 TZ-261 Tape Recorder Cleaner Kit



Fig. 2-6 TZ-255 Oil Kit

3. PARTIAL DIS-ASSEMBLY OF MAIN PARTS

NOTE

1. Use the proper tools. Demagnetize the tools before use.
2. When mounting or removing a spring, pay heed to the position (direction) of the anchor or hook. The wrong position may result in a change in the tension.
3. When reassembling, don't forget to reinstall all hardware such as springs and washers, etc.
4. For assembling hardware shape identification, see ASSEMBLING HARDWARE CODING LIST on the Parts List.

3-1. CASE/FRONT PANEL

Remove the parts in the following sequence.

1. Left and right Sideboards (C and E)
2. Head Cover (B)
3. Cassette Storage Tray (A)
4. Trim Case Cover (D)
5. Bottom Cover (H)
6. Six Knobs (G)
7. Front Panel (F)

When removing or installing the Front Panel, set the BIAS/EQ Switches to the 2 position and other switches to the upper position to make work easier.

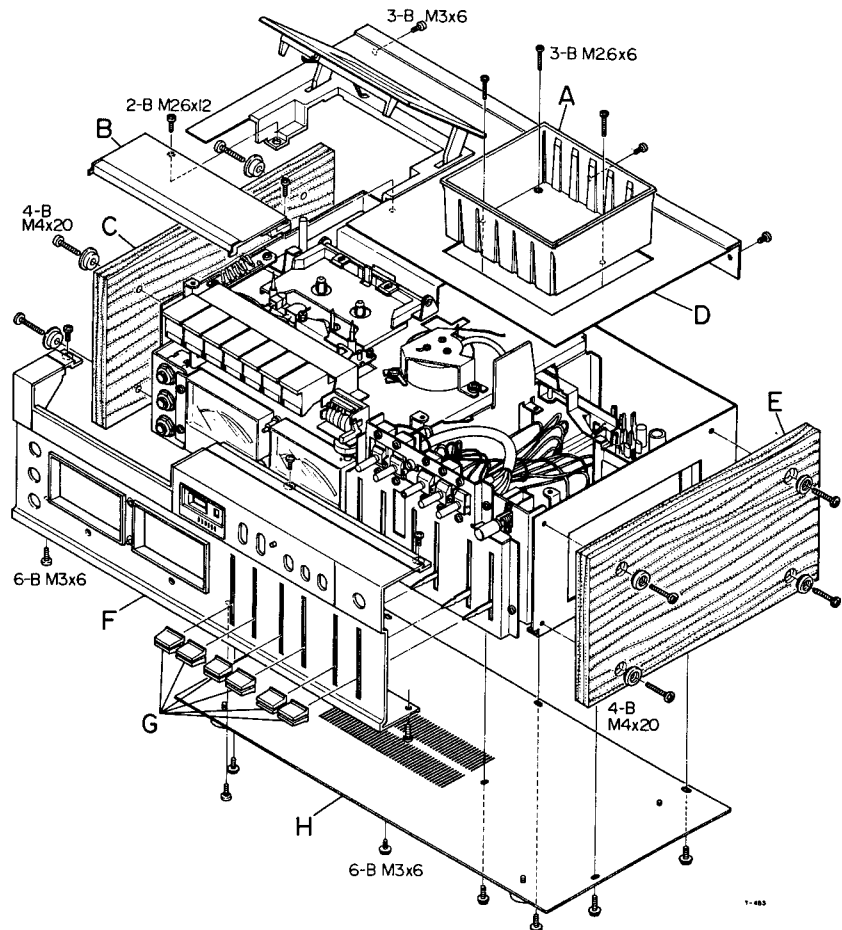

Fig. 3-1 Case/Front Panel Removal

3-2. MOTOR

1. Remove the Trim Case Cover. See the above section.
2. Release the Drive Belt from the Motor Pulley.
3. Unsolder the 3 wires of the Motor Ass'y from the 2L-5P terminal strip located inside of the main chassis. Note the color code and the position of each wire prior to unsoldering the Motor leads.
4. Lift the Motor Ass'y out of the chassis.

NOTE

1. When re-assembling, clean the pulley and the Belt with TEAC TZ-261 Cleaner kit ("A" for the Pulley, "B" for the Belt) or with pure alcohol.
2. Take off or remount the Motor Ass'y taking care not to scratch or otherwise damage the Motor Pulley.
3. When re-attaching the Drive Belt to the Pulley do not twist or stretch the belt.

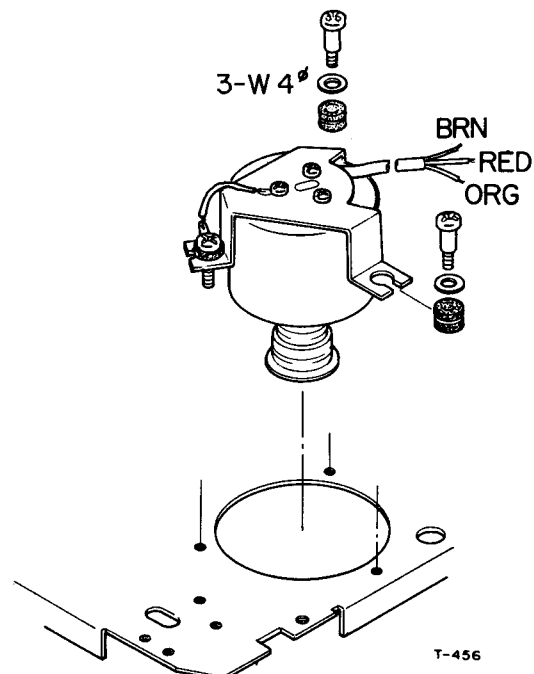

Fig. 3-2 Motor Replacement

3-3. CASSETTE HOLDER

1. Remove the Trim Case Cover. See 3-1 Section on page 6.
2. Loosen the screw (G) and then partially turn the Stopper Bracket (H) in the direction of the arrow to enable the Cassette Holder (D) to be readily removed.
3. Remove the Spring (E) from the hook (C) of the Cassette Holder.
4. Remove the other end of the Spring (E) from the Lever (F) to retain it.
5. Remove the Cassette Holder Shaft (A) by taking off the 2 E-rings to separate the Cassette Holder from the Cassette Holder Retainer (B).
6. Remove the Cassette Holder from the Retainer.
7. If necessary, remove the Retainer from the chassis by taking off the 2 screws.

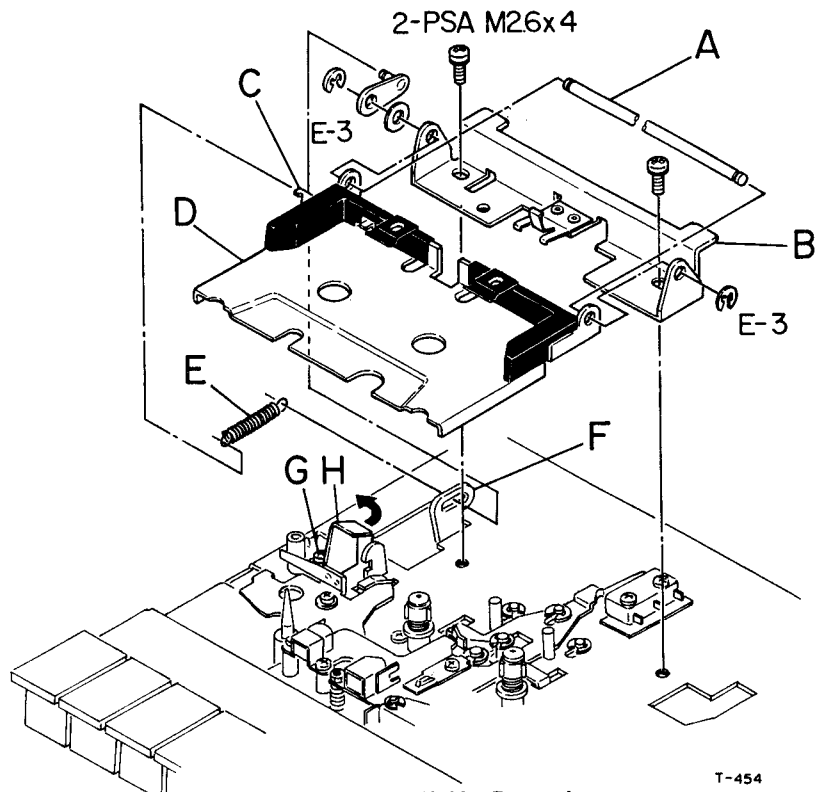

Fig. 3-3 Cassette Holder Removal

3-4. HEAD/PINCH ROLLER

3-4A. HEAD

1. Remove the E-ring (A) and remove the Spring (C) from the hook (D) of the Head Base Plate and the tab of the Pinch Roller Ass'y (B).
2. Remove the Pinch Roller Ass'y from the pivot stud pin (E).

3-4B. PINCH ROLLER

After removing the Trim Case Cover (see 3-1), do the following procedure.

1. Unsolder each lead wire from the terminal pin of the heads to facilitate replacement. To re-solder each head wire to the newly replaced head, refer to Fig. 3-5.
2. Lift up the heads after taking off the hardware mounting them. When removing the nut, do not loose Washer (F) and Spring (G).

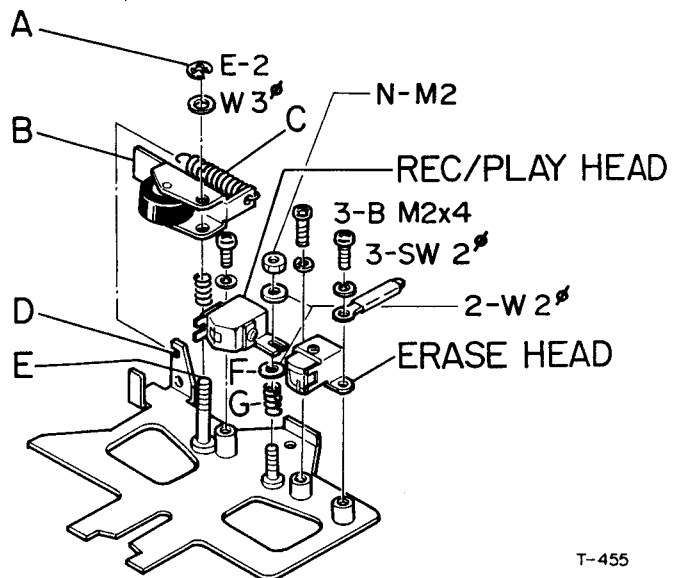

Fig. 3-4 Head/Pinch Roller Replacement

NOTE

1. After replacing the head, always adjust the head alignment especially the Record/Playback Head's azimuth (see 7-1-1), and then secure the screws and/or the nut with a drop of locking paint.

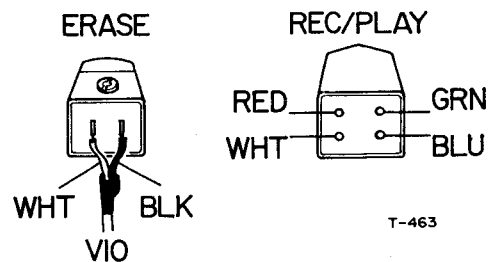

Fig. 3-5 Head Wiring Diagram

2. Connect the wires to the head terminal pins quickly to prevent breaking of internal wires of the head due to overheating.
3. After replacement, always clean the driving surfaces of the Pinch Roller with the TEAC TZ-261B Rubber Cleaner or with pure alcohol, then proceed directly to the PINCH ROLLER PRESSURE adjustment section. See page 11.

3-5. BRAKE BRACKET

1. Remove the Trim Case Cover. See 3-1 section.
2. Remove the Cassette Holder. See 3-3 section.
3. Detach the 2 E-rings (A) and then take off the Spring (B) and the Brake Bracket (C) from the chassis.
4. Remove each Brake Shoe (D) from the Brake Bracket.

3-6. CAPSTAN DRIVE ASS'Y/DRIVE BELT

1. Remove the Bottom Cover. See 3-1 section.
2. Detach the Flywheel Bearing Plate (A) from the mounting studs (D and F) by taking off the 2 screws.
3. Take out the Drive Belt (C) from the Flywheel (B) and the Motor Pulley (G).
4. Carefully lift out the Flywheel from the Capstan Housing Ass'y (E).
5. Remove the Capstan Housing Ass'y from the chassis by unscrewing the 3 screws.

NOTE

1. Since the Capstan Drive Ass'y is a precision part, TEAC specially distributes the Flywheel and the Capstan Housing Ass'y as a whole assembly. Hence, always replace the Flywheel together with the Capstan Housing Ass'y.
2. Clean all driving surfaces of the Flywheel and the Drive Belt with TEAC TZ-261 Cleaner kit ("A" for Flywheel. "B" for Belt) or with pure alcohol.
3. Do not bend the Capstan Shaft as this will increase wow/flutter or speed deviation.
4. During re-assembly re-attach the Drive Belt without twisting or stretching it.
5. The Belt should always be attached right and in the predetermined place.

Lubrication:

For lubrication of the newly replaced Capstan Drive Ass'y, the following should be observed.

1. Apply a drop of a light machine oil of good quality (e.g.: TEAC TZ-255) with an oil applicator to the shaft of the Flywheel and spread oil evenly over the shaft with a flannel cloth. After installing the Flywheel, be sure to clean the tape moving portion of shaft with TEAC TZ-261A Head Cleaner or with pure alcohol.

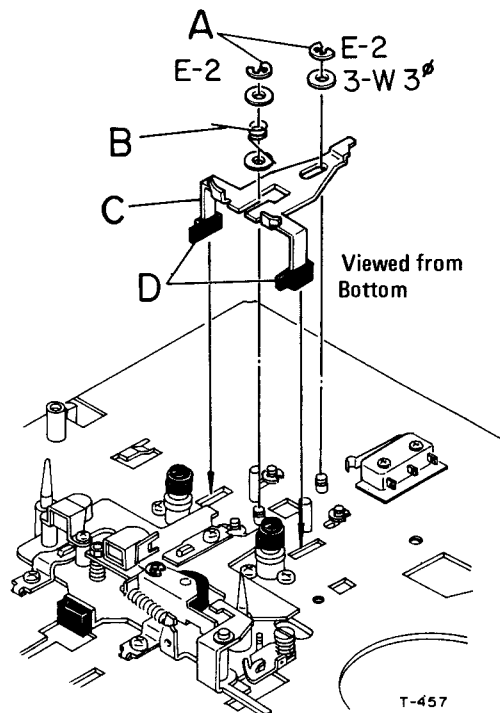

Fig. 3-6 Brake Bracket Removal

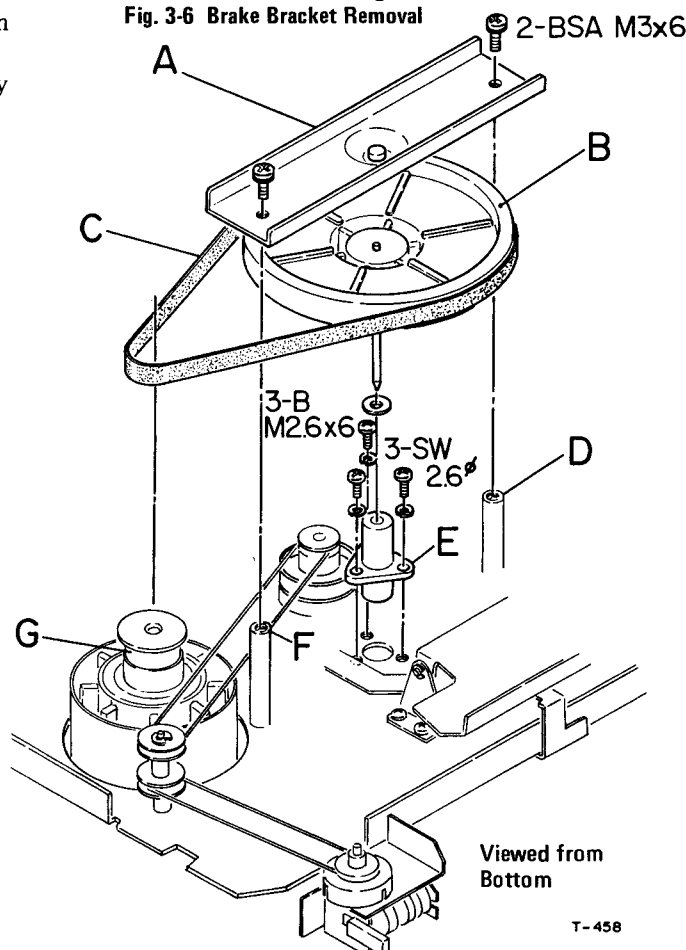

Fig. 3-7 Capstan Drive Ass'y/Drive Belt Replacements

2. Apply a drop of the proper oil in the same way as above to the innermost area of capstan shaft (next to the Flywheel).
3. Apply a film of light grease to the well of the Flywheel Bearing Plate.

3-7. REEL TABLE

1. Remove the Trim Case Cover. See 3-1 section.
2. See Fig. 3-8 for step 2 to 4. Remove the Spring (A) from the hook (B) of the Cassette Holder (D).
3. Loosen the screw on the Stopper Bracket (C) and then partially turn the Bracket in the direction indicated by the arrow.
4. Rotate the Cassette Holder away from the Reel Tables (E and F).
5. Remove the Bottom Cover. See 3-1 section.
6. Remove the Drive Belt and the Flywheel. See 3-6.
7. See Fig. 3-9 for step 7 to 9. When only the Supply Reel Table (J) is to be removed, first take out the Back

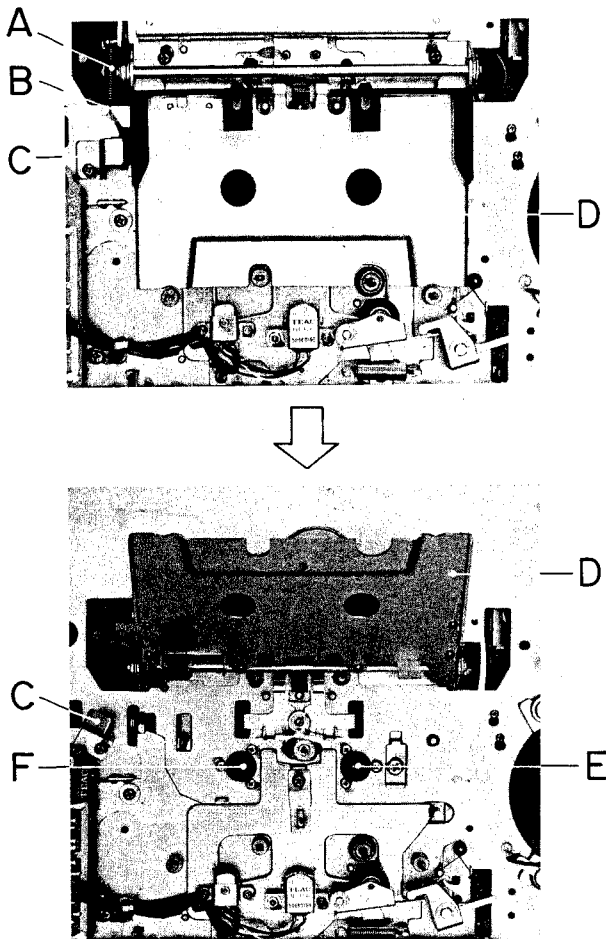

Fig. 3-8 Rotation of Cassette Holder

8. For Detaching the Take-up Reel Table (K), first take out the Large Counter Belt (L).
9. Take off the screws mounting the Reel Table which requires replacement; next, with the PLAY key depressed to release the Brake Shoes (M) from the Reel Tables, pull out the table.

NOTE

Always replace the complete Reel Table Ass'y as an entire assembly, "Take-up" or "Supply".

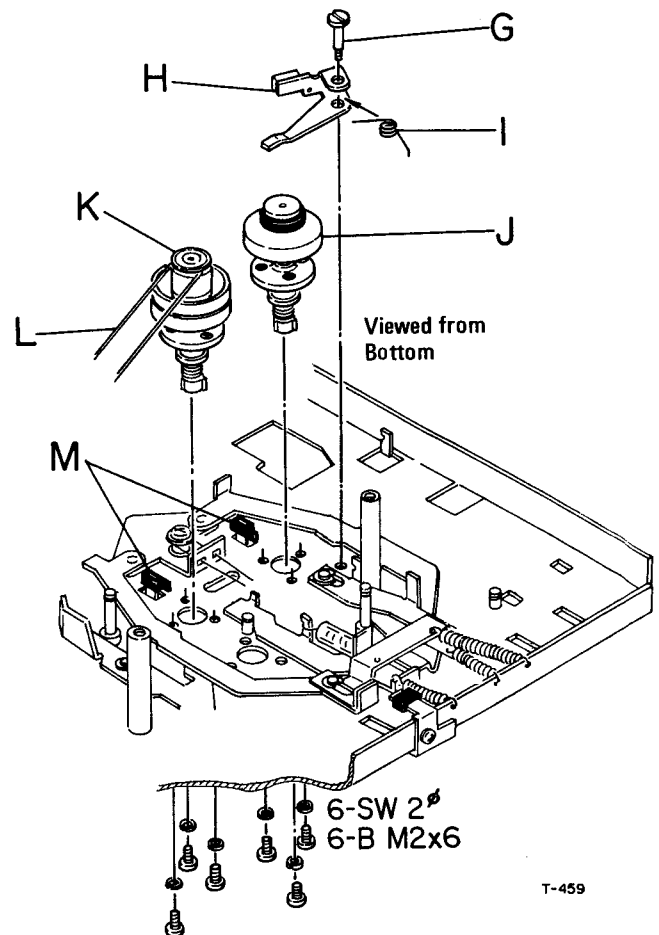

Fig. 3-9 Reel Tables Replacement

3-8. FAST WIND ROLLER ASS'Y

1. Remove the Trim Case Cover. See 3-1 section.
2. Rotate the Cassette Holder away from the Reel Tables. See 3-7 section on page 9.
3. Remove the Bottom Cover. See 3-1 section.
4. Remove the Drive Belt and the Flywheel. See 3-6.
5. Remove the Spring (C) from the hook (G) of the F.F. Lever.
6. Gently take off the 2 E-rings (B and H) and lift out the Fast Wind Roller Ass'y (A) from the stud (F). In doing this do not tilt the assembly at any angle as this may damage the Roller Pin (D) and the Spring (E) or cause them to be bent or broken.
7. If it is necessary to further disassemble the Fast Wind Roller Ass'y, refer to the DETAIL OF "A" figure.

NOTE

During remounting of the removed Fast Wind Roller Ass'y, do the following:

1. Lubricate the entire shaft with a thin application of light machine oil. (e.g.: TEAC TZ-255)
2. Clean the Fast Wind Belt and all friction surfaces of the Rollers with TEAC TZ-261B Rubber Cleaner or with pure alcohol before re-installing the Belt.

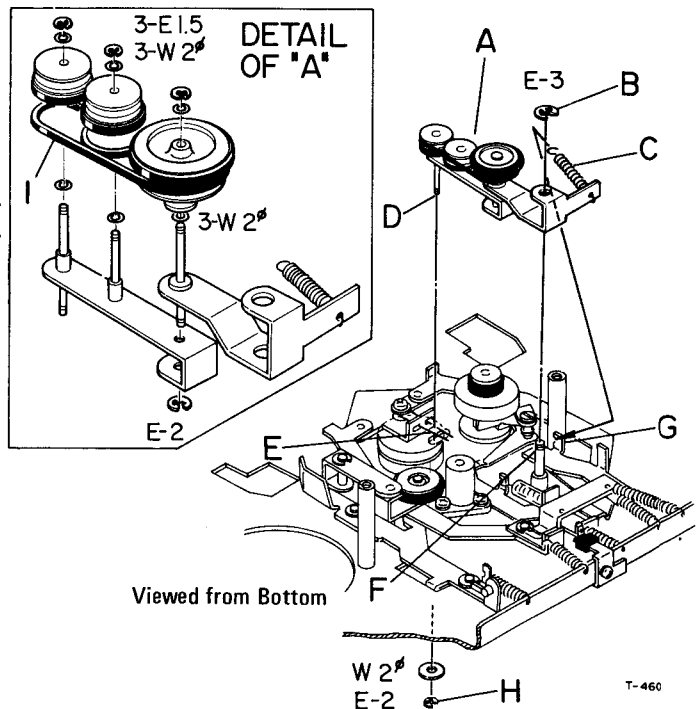

Fig. 3-10 Fast Wind Roller Ass'y Replacement

3-9. POWER TRANSFORMER

1. Remove the Trim Case Cover and the Bottom Cover. See 3-1 section on page 6.
2. Unsolder each wire of the Power Transformer (B). Note the color code and position of each wire prior to unsoldering the Transformer leads.
3. Take off the 4 screws (G) and remove the complete Transformer Ass'y (A) from the main chassis.
4. Separate the Transformer body and the Mounting Plates (D, E, F) by taking off the 2 screws (C).

NOTE

When reinstalling the new Transformer, loosely tighten the 2 screws (C) to attach the Transformer body and the mounting plate (E). Then after attaching the complete Transformer Ass'y (A) to the main chassis, position the transformer body by sliding it in either direction as shown by the arrows to find the position that produces the lowest hum. After this, firmly tighten the 2 screws (C).

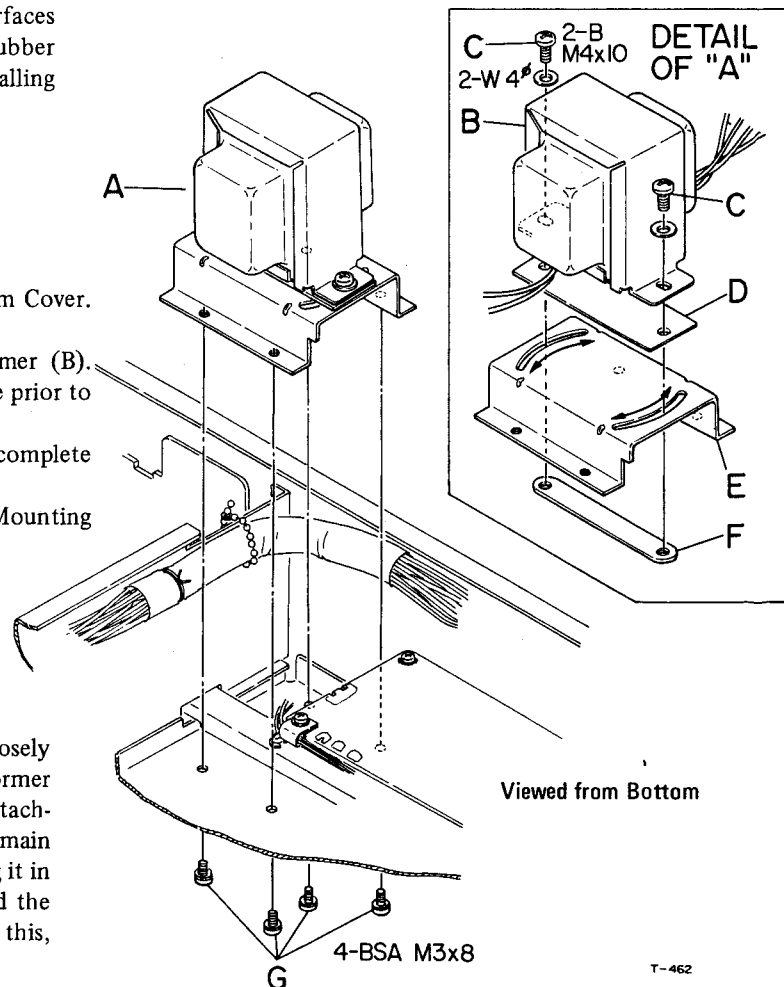

Fig. 3-11 Power Transformer Replacement

3-10. PLAY IDLER ASS'Y

1. Remove the Bottom Cover. See 3-1 section.
2. Take out the Drive Belt and the Flywheel. See 3-6.
3. Lift off the Play Idler Ass'y (B) with the Spring (C) removed from the mounting pin (E) and the E-ring (A) taken off from the pivot stud pin (D).
4. For further disassembly of the Play Idler Ass'y, refer to the DETAIL "B". When remounting, clean the driving surface of the Idler with the TEAC TZ-261B Rubber Cleaner or with pure alcohol.

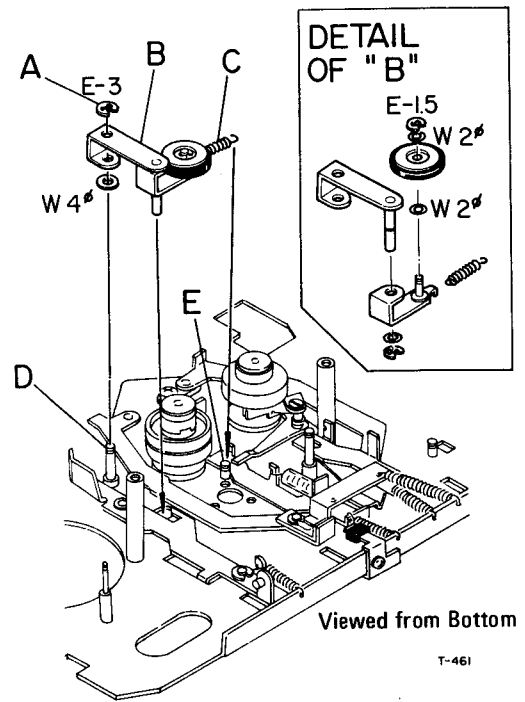

Fig. 3-12 Play Idler Ass'y Replacement

4. MECHANICAL CHECKS AND ADJUSTMENTS

NOTE

All the mechanical checks and adjustments should be done with the Trim Case Cover removed. (See Section 3-1)

4-1. PINCH ROLLER PRESSURE

Specification: 400 g ± 20 g (13.5 ~ 15.0 oz.)

1. Switch on POWER.
2. Place the deck in the PLAY mode with no tape loaded.
3. Attach the spring scale to the Pinch Roller shaft as shown in Fig. 4-1.
4. Gently pull the scale away (in the direction of the arrow) until the Capstan shaft and the Pinch Roller are completely separated.
5. Gradually release the tension on the scale until the Pinch Roller just begins to rotate. The scale should then be reading approximately 400 g ± 20 g (13.5 ~ 15.0 oz.).
6. If the reading is out of specified range, adjust the tension of the Pressure Spring by bending the tab of the Pinch Roller Ass'y slightly.

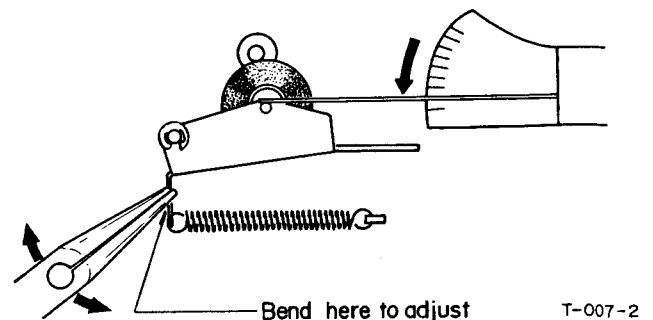

Fig. 4-1 Pinch Roller Pressure Measurement

4-2. TAKE-UP TORQUE

Specification: 40 ~ 70 g·cm (0.6 ~ 1.0 oz·inch)

1. Rotate the cassette holder away from the reel tables. See 3-7 section.
2. Switch on POWER.
3. Set the Cassette Reel Adapter (22 mm Dia.), connected to the spring scale (0 ~ 70 g, or 0 ~ 2.5 oz.) by the string as shown in Fig. 4-2 on the Take-up Reel Table.
4. Place the deck in the PLAY mode.
5. Allow the rotation of the Reel Table to pull the scale pointer toward the Adapter with the spring scale moving in the same direction at nearly the same speed as the tape would be moved, and obtain the scale reading. Make reading only when the pointer becomes stable.
6. The scale should indicate Force of 36 ~ 64 g (1.3 ~ 2.2 oz.). This corresponds to a torque of 40 ~ 70 g·cm (0.6 ~ 1.0 oz·inch). For the torque calculation, refer to Fig. 4-3.
7. If the reading is out of specified range, clean the driving surfaces of the Reel Table Ass'y, and all other driving parts relative to the take up torque function with the TEAC TZ-261B Rubber Cleaner or with pure alcohol
8. If the above cleaning is ineffective for torque correction, replace the Reel Table Ass'y. (See Section 3-7)

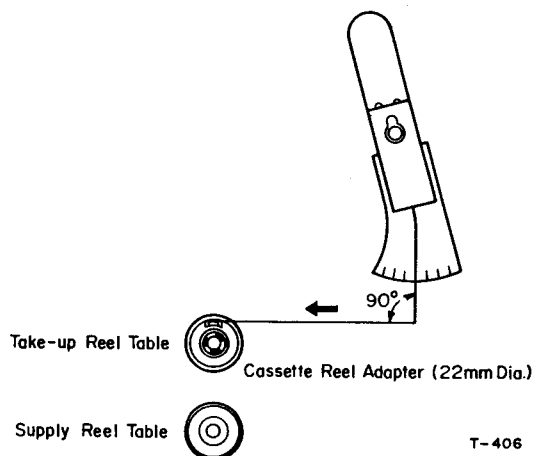
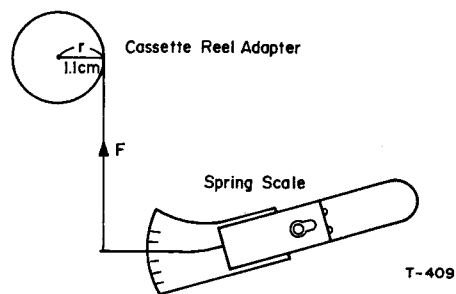

Fig. 4-2 Take-up/Fast Forward Torque Measurement

4-3. FAST FORWARD TORQUE

Specification: 100 g·cm (1.4 oz·inch) or more

1. Repeat step 1 and 2 in 4-2 above.
2. Set the Cassette Reel Adapter (22 mm Dia.), connected to the spring scale (0 ~ 200 g, or 0 ~ 7.0 oz.) by the string as shown in Fig. 4-2, on the Take-up Reel Table.
3. Place the deck in the Fast Forward mode.
4. Allow the rotation of the Reel Table to pull the scale pointer toward the Adapter, and obtain the scale reading. Do not read until the pointer becomes stable.
5. The scale should indicate 91 g (3.2 oz.) or more. This corresponds to a torque of 100 g·cm (1.4 oz·inch) or more.
6. If the indication is out of specified range, clean the driving surfaces of the Reel Table Ass'y and all other driving parts relative to the fast forward torque function with the TEAC TZ-261 B Rubber Cleaner or with pure alcohol.
7. If the above cleaning is ineffective for the torque correction, bend the spring (see Fig. 4-5) to get the specified torque value.



$$T = F \times r$$

T: torque (g·cm)

F: force (g)

r: radius (cm)

For example:

If F = 41 g

$$T = F \times r$$

$$= 41 \times 1.1$$

$$\approx 45 \text{ (g·cm)}$$

Consequently the torque is 45 g·cm.

Fig. 4-3 Torque Calculation Method

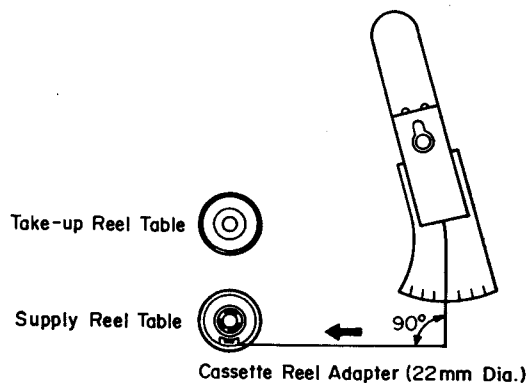

Fig. 4-4 Rewind Torque Measurement

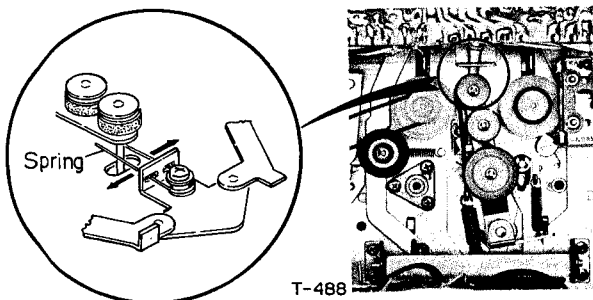

Fig. 4-5 F. FWD & Rewind Torque Measurement

4-4. REWIND TORQUE

Specification: 100 g cm (1.4 oz·inch) or more

1. Repeat the 4-3 procedure, but use the Supply Reel Table and Rewind mode for measuring the rewind torque. (See Fig. 4-4)
2. The specified value is the same as that of the fast forward torque. See step 5 in 4-3.

TORQUE MEASUREMENT USING THE CASSETTE TORQUE METER

The torque measurements can be easily done with the Cassette Torque Meter indicated below.

For take-up torque measurement: 0 ~ 100 g·cm

For fast forward and rewind torque

measurements: 0 ~ 160 g·cm

By use of this, it is possible to directly obtain the torque value without calculation, and to do the measurement simply with no removal of any parts. If repairs are necessary, the Trim Case Cover and the Bottom Cover must be removed.

Load the Meter on the deck and read the pointer indication on the dial scale for each tape movement operation.

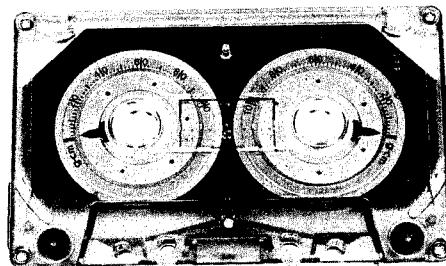

Fig. 4-6 Cassette Torque Meter

4-5. BRAKE TENSION

1. Switch on POWER.
2. Load a TEAC MTT-501 test tape.
3. Check for excess slack or tightness of the tape when operation is changed from play, fast forward and rewind mode to stop mode, respectively.
4. If brake action is too "tight" or "loose", adjust by bending the arms of the Brake Bracket in or out as shown by the arrows in Fig. 4-7.

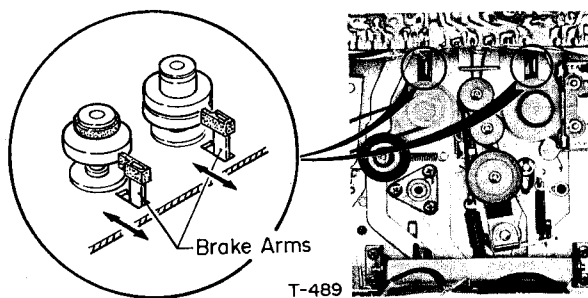

Fig. 4-7 Brake Tension Adjustment

4-6. TAPE SPEED/WOW AND FLUTTER

Specification:

Tape Speed Deviation: 3,000 Hz \pm 30 Hz
 Wow and Flutter: Playback: 0.07% (WRMS)
 Record/Playback: 0.10% (WRMS)

NOTE

1. Before performing this adjustment, clean all parts in the tape path, particularly the Capstan, the Pinch Roller and the Heads with the appropriate liquid from the TEAC TZ-261 Cleaner Kit or with pure alcohol.
2. Wow and flutter should be checked in two ways; Playback only and Record/Playback methods. First check, and correct if necessary, tape speed and wow and flutter using the playback only method. Then measure wow and flutter using record and playback method.
3. As the measured results may vary with respect to location on tape at which it was taken, three points – at beginning, middle and near the end of the tape – should be measured.

4-6-1. TAPE SPEED

1. Connect test equipment to the deck, except the AF oscillator, as shown in Fig. 4-8.
2. Set the OUTPUT control on the deck to proper setting.
3. Set the EQ switch to the "3" position, and then load and play a TEAC MTT-111 test tape (3,000 Hz signal recorded).
4. Verify the reading on the frequency counter is within the specified range of 3,000 Hz \pm 30 Hz.
5. If the tape speed is extremely out of the specification, check the Pinch Roller pressure and the tape driving function for correction, and make sure the tape path is clean.

4-6-2. WOW AND FLUTTER

After making the tape speed measurement, perform the wow and flutter test using the Playback Method and the Record/Playback Method successively.

PLAYBACK METHOD

1. Repeat steps 1 – 3 in 4-6-1.
2. Read the indication on the wow and flutter meter.
3. The wow and flutter value should be 0.07% WRMS, max.
4. If the wow and flutter is out of the specification, check the Pinch Roller pressure and the take-up torque, and see that the tape path is clean, and that the Capstan Belt is not stretched or oily.
5. If the above checks are ineffective for excessive wow and flutter correction, repair or replace the Pinch Roller, the Capstan Belt and/or any other defective parts.

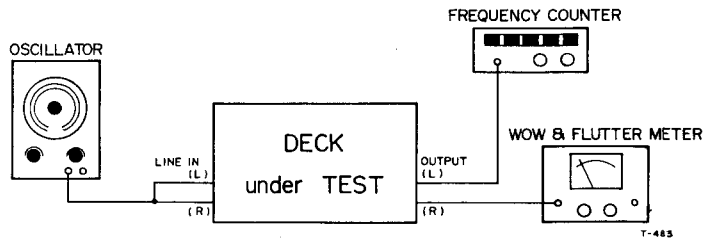

Fig. 4-8 Tape Speed/Wow and Flutter Measurement Setup

RECORD/PLAYBACK METHOD

NOTE

When using this method, adopt the maximum wow and flutter value obtained by repeated play and stop modes of operation. This operation is necessary to make sure wow and flutter content between record and playback will not be in phase to create a false reading.

1. Connect test equipment to the deck as shown in Fig. 4-8.
2. Set both LINE and OUTPUT controls on the deck to proper setting.
3. Load a TEAC MTT-502 test tape (blank) and set the BIAS/EQ switches in the "3" positions.
4. Apply and record a 3,000 Hz signal.
5. Rewind and play this recorded portion.
6. Read the indication on the wow and flutter meter.
7. The wow and flutter value should be 0.10% WRMS, max.
8. If the measured value is out of the specification, repair using the same methods as stated in steps 4 – 5 in the Playback Method procedure.

BOTTOM VIEW w/ FLYWHEEL REMOVED

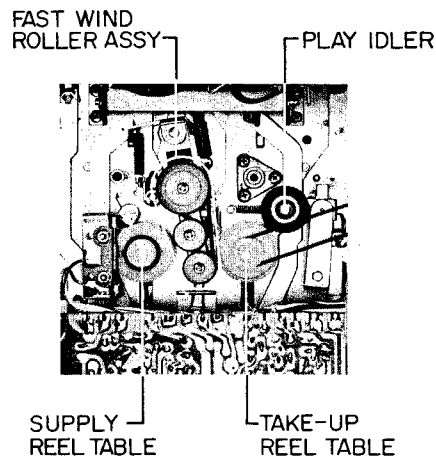
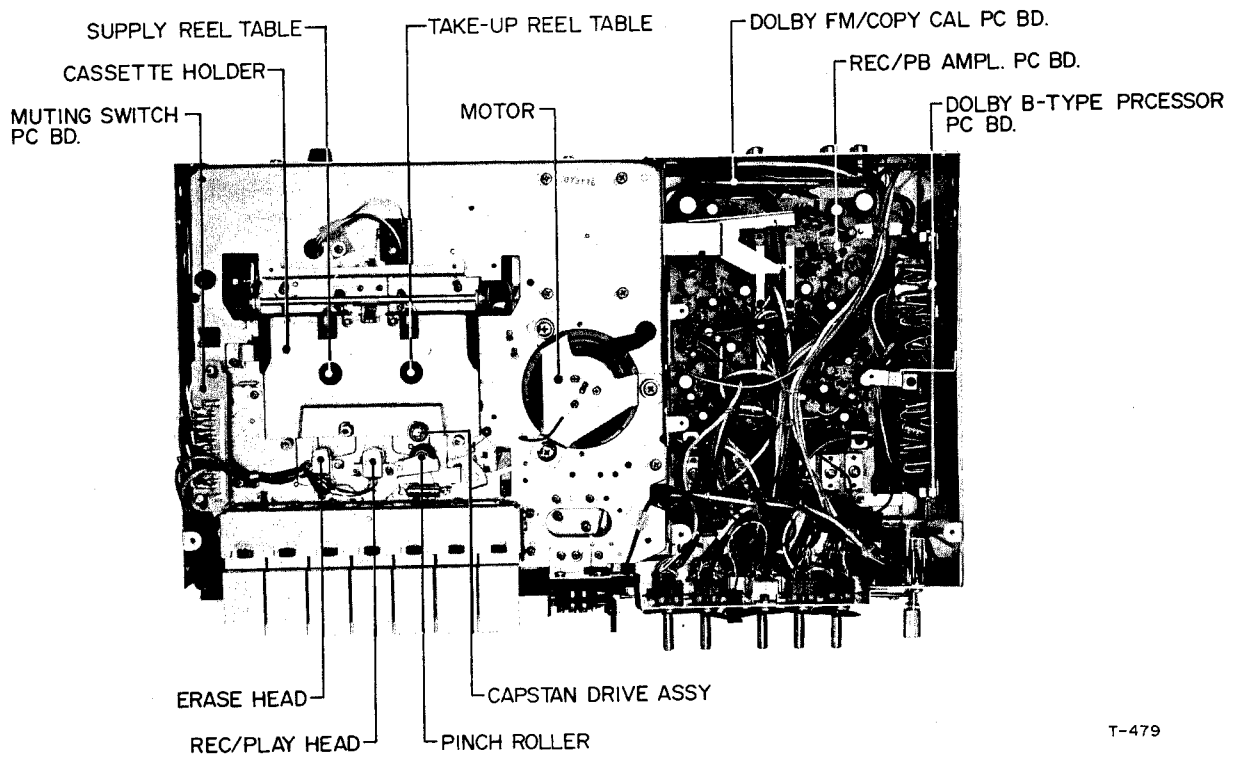

Fig. 5-1 Bottom View w/Flywheel Removed

5. PARTS LOCATION

TOP VIEW



T-479

Fig. 5-2 Top View

BOTTOM VIEW

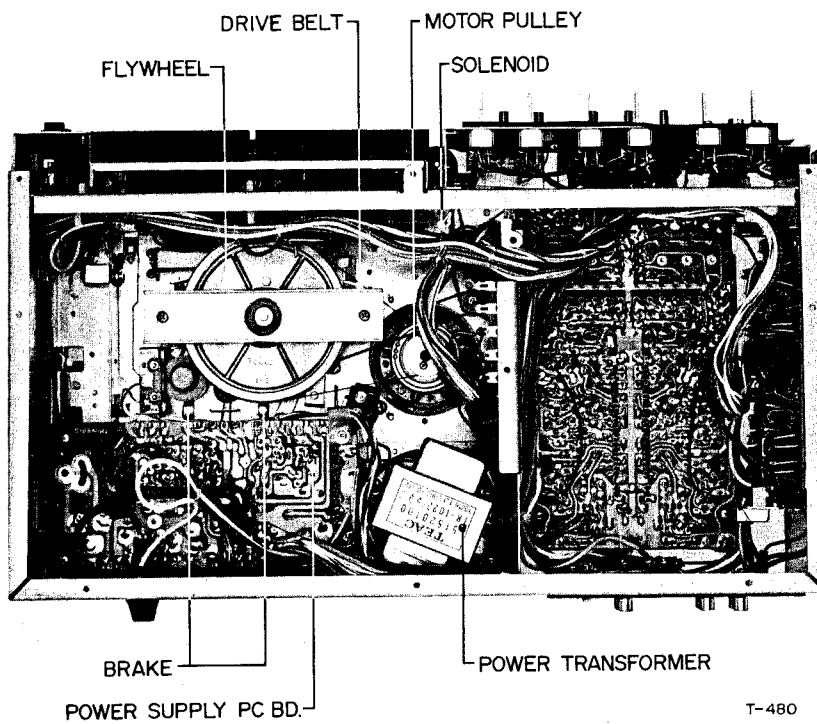

T-480

Fig. 5-3 Bottom View

6. LUBRICATION

NOTE

1. Lubrication should be generally done at about every 1,000 hours of operating time of the tape deck. Use high quality oil for this purpose.
2. For efficient oiling, it is recommended that lubrication be done after nearly 1 hour of idling of the deck.
3. No other lubrication is normally necessary with the following exceptions.

6-1. MOTOR

Apply 1 or 2 drops (approx. 0.2 cc) of a light machine oil with an oil applicator to the oiling hole of the Motor.

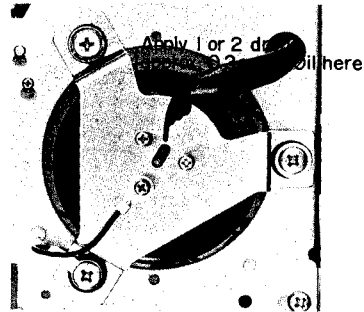

Fig. 6-1 Lubrication of Motor

6-2. CAPSTAN ASS'Y

Apply 1 or 2 drops (approx. 0.2 cc) of a light machine oil with an oil applicator to the shaft bearing portion of the Capstan Assy.

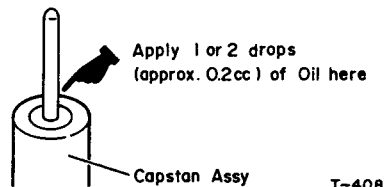

Fig. 6-2 Lubrication of Capstan Ass'y

6-3. FLYWHEEL ASS'Y

See Section 3-6 for lubrication of the newly replaced Flywheel Assy.

7. ELECTRICAL CHECKS AND ADJUSTMENTS

GENERAL NOTICE

1. Before performing adjustments on the amplifier section of this deck, thoroughly clean and demagnetize the entire tape path, particularly erase head, record/playback head, capstan shaft and pinch roller.
 2. Make sure the deck is set for the proper voltage and frequency for your locality.
 3. In general, checks and adjustments for other than specified items, are done in the sequence of left channel then right channel. Double designated REF. NO. indicates left channel/right channel (example: VR101/201).
 4. Value of "dB" in the text refers to 0 dB = 0.775 V, except where specified. If a VTVM calibrated to 0 dB = 1 V is to be used, appropriate compensation should be made.
 5. The VTVM used in the procedures, including the measurement at CAL test points, must have load impedance of 1 M Ω or more.
 6. To correctly complete these performance checks, keep the order as explained in this chapter.
 7. All checks and adjustments should be made with all Cabinet parts, except for the Front Panel, removed. (See Section 3-1)
- * For each procedure, make the initial equipment test set up, connections and switch/control settings as shown in the associated illustrations.
- ** Each of the switches shown in the boxed-in area of the photograph have effect on the procedures.

7-1. PLAYBACK PERFORMANCE

NOTE

Except for the Playback Frequency Response checks, all alignments in the **PLAYBACK PERFORMANCE** only have to be done with the EQ switch set to position 3 unless there is a special reason which requires that other positions also be checked.

7-1-1. RECORD/PLAYBACK HEAD AZIMUTH ADJUSTMENTS

1. Load and play a TEAC MTT-150 test tape.
2. Make sure the phase relationship between the 2 signals (left channel and right channel) is within 45° on the oscilloscope.
3. Load a TEAC MTT-116U test tape.
4. Play the 10 kHz signal section of the tape.
5. Slowly adjust the azimuth adjusting nut for the maximum indication on the VTVM.
6. Secure the nut with a drop of locking paint.

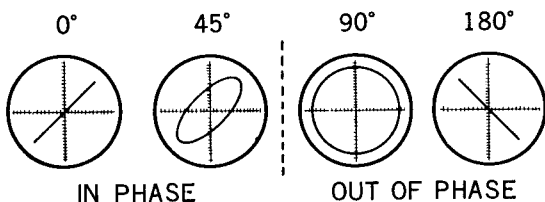

Fig. 7-1 Confirming Phase Relationship

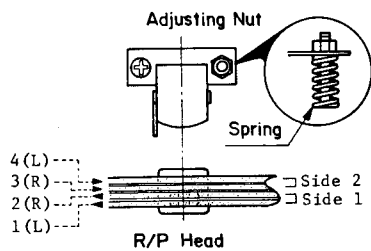

Fig. 7-2 Head Azimuth Adjustments Location

7-1-2. SPECIFIED OUTPUT LEVEL SETTING

1. Load and play a TEAC MTT-150 test tape.
2. Adjust VR102/202 for 100 mV (-18 dB) on VTVM connected to the CAL test points.
3. Change the VTVM connection to the OUTPUT jacks.
4. Set the OUTPUT controls fully clockwise.
5. Confirm that the output level is $-3.5 \text{ dB} \pm 1 \text{ dB}$ (461 mV \sim 580 mV).
6. Set the OUTPUT controls for a reading of -5 dB (435 mV). This is the specified output level. At this time, the physical position of the OUTPUT controls indicates the Specified Control Settings referred to in subsequent procedures.

IMPORTANT

After this setting is done, do not disturb the Specified Control Setting of the OUTPUT controls until the remaining checks and adjustments are completed.

CONNECTION

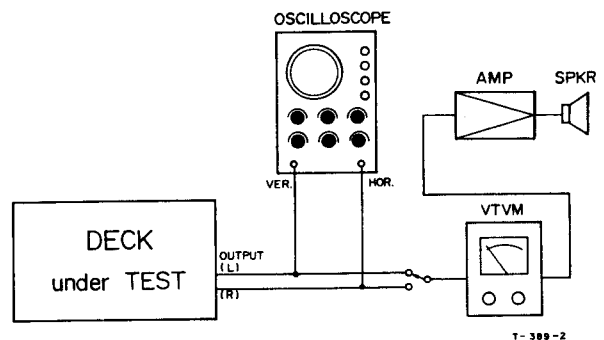
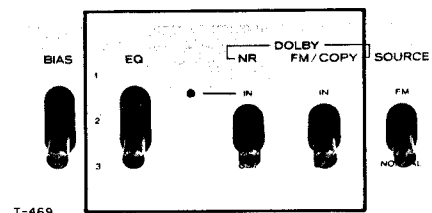

Fig. 7-3 Connection

SWITCH & CONTROL SETTING:



OUTPUT Control: Proper setting

CONNECTION

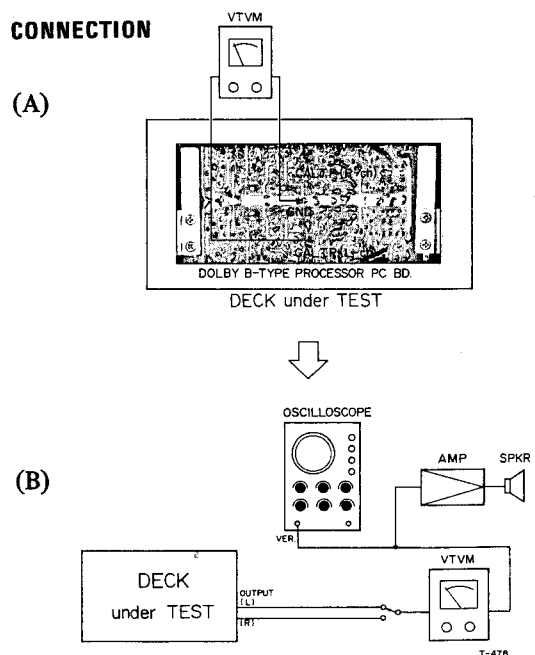

Fig. 7-4 Connections

SWITCH & CONTROL SETTING: Same as 7-1-1.

7-1-3. VU METER CALIBRATION –PLAYBACK–

7. Adjust VR107/207 for +3 VU (□) on the VU meter.
8. Set the DOLBY NR switch to the IN position and make sure the VU meter indication is the same, also.

7-1-4. FREQUENCY RESPONSE –PLAYBACK–

NOTE

In the following procedure, adjust VR101/201 so that the measured values on all setting of the EQ switch are within the specified response limits.

Hi-Fi TAPE

9. Load a TEAC MTT-116U test tape and play its test signals from 40 Hz up to 14 kHz.
10. Adjust VR101/201 so that the readings of the higher frequency signals on the VTVM are within the response limits.

CrO₂ & Fe-Cr TAPES

11. Repeat the above procedure, with the following exceptions.

Test tape: MTT-116K
EQ switch: Both "1 & 2" positions

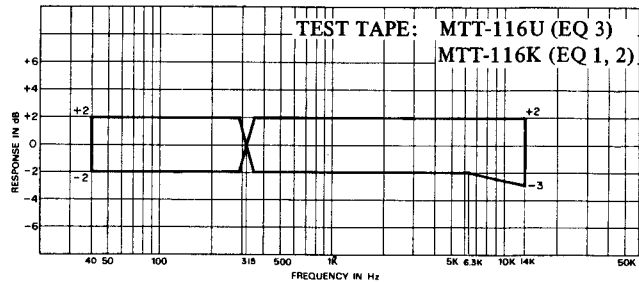

Fig. 7-5 Playback Frequency Response Limits

NOTE

If the response does not meet the specified response limits, the head should be checked for accumulated oxide or dirt. Then, if no dirt is found, the head azimuth should be readjusted.

7-1-5. SIGNAL TO NOISE RATIO –PLAYBACK–

1. Place the deck in the PLAY-PAUSE mode.
2. Read the indication on the VTVM.
3. The VTVM should indicate -52 dB minimum (1.94 mV maximum).
4. This corresponds to a signal-to-noise ratio of 47 dB (minimum): difference between residual noise -52 dB and the specified output level -5 dB (435 mV).

NOTE

Since the polarity of the AC plug has some effect on the signal-to noise ratio, the plug can be reversed in the wall socket when checking the signal-to-noise ratio. The worse case value should be within the indicated value above.

Specification: 47 dB (minimum)

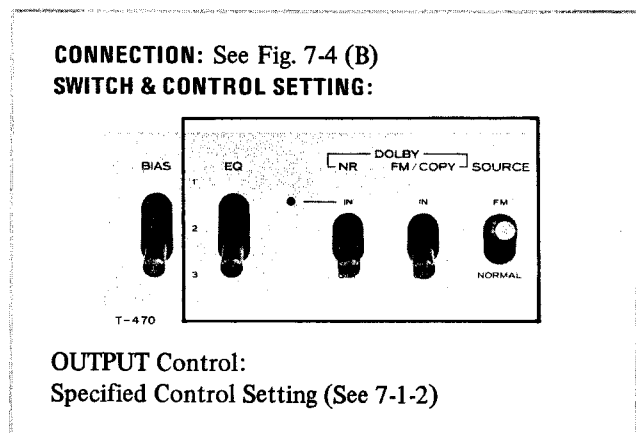

7-1-6. HEADPHONE OUTPUT LEVEL CHECKS

NOTE

An 8 ohm non-inductive resistor should be used as the test load resistor.

1. Load and play a TEAC MTT-150 test tape.
2. Measure the level across the test load resistor.

Specification: $-21 \text{ dB} \pm 2 \text{ dB}$ (54.8 mV – 86 mV)

CONNECTION

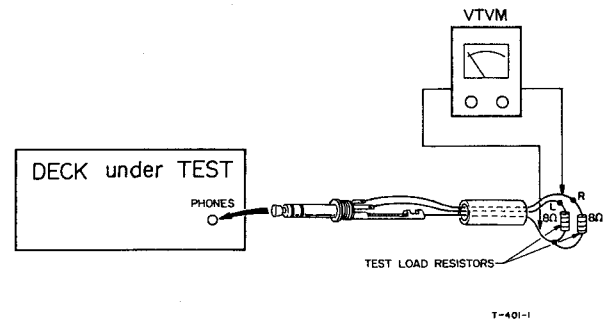
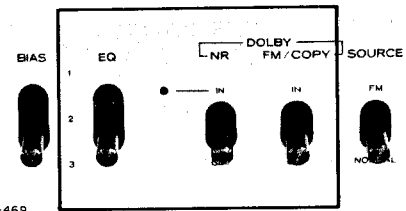

Fig. 7-6 Connection

SWITCH & CONTROL SETTING:



OUTPUT Control: Specified Control Setting (See 7-1-2)

7-2. MONITOR PERFORMANCE

7-2-1. MINIMUM INPUT LEVEL CHECKS

NOTE

To prevent mis-measurements for the following procedures, any connection cords other than these for the respective input check must be removed. For example: Do not connect the Microphone and the DIN cords to respective input jacks when checking for the LINE inputs.

1. Load any recordable tape.
2. Place the deck in the RECORD-PAUSE mode.
3. Set the MIC controls to maximum.
4. Apply a 400 Hz signal at $-67 \text{ dB} \pm 2 \text{ dB}$ ($274 \mu\text{V} \sim 435 \mu\text{V}$) to the MIC jacks and check for 100 mV (-18 dB) on the VTVM connected to the Dolby test points. (Minimum Input Level checks for the MIC jack)
5. Apply a 400 Hz signal at $-35 \text{ dB} \pm 2 \text{ dB}$ ($10.9 \text{ mV} \sim 17.3 \text{ mV}$) to the input terminals of the DIN connector and check for 100 mV. (Minimum Input Level checks for the DIN inputs)
6. After checking, reduce the MIC controls to minimum to prevent noise insertion during subsequent procedures.
7. Set the LINE controls to maximum.
8. Apply a 400 Hz signal at $-15 \text{ dB} \pm 2 \text{ dB}$ ($109 \text{ mV} \sim 173 \text{ mV}$) to the LINE IN jacks and check for 100 mV. (Minimum Input Level checks for the LINE inputs)

CONNECTION

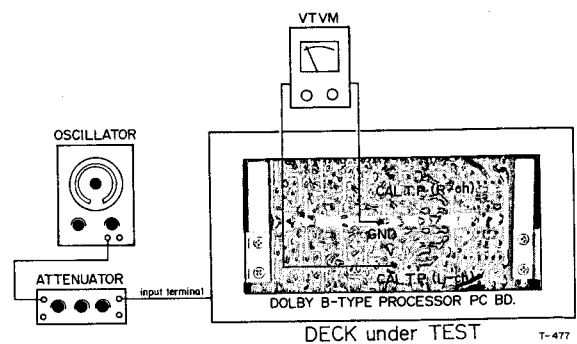
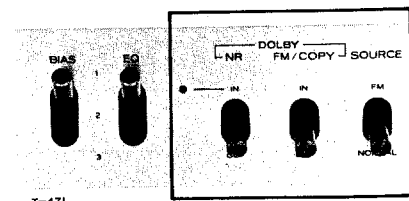

Fig. 7-7 Connection

SWITCH & CONTROL SETTING:



OUTPUT Control: Specified Control Setting (See 7-1-2)
 LINE Control: Minimum Setting
 MIC Control: Minimum Setting

7-2-2. SPECIFIED LINE CONTROL SETTING

9. Apply a 400 Hz signal at -5 dB (435 mV) to the LINE IN jacks. See Fig. 7-8.
10. Set the LINE controls to obtain the reading of 100 mV (-18 dB) on the VTVM. At this time, the physical position of the LINE controls indicates the Specified LINE Control Setting referred to in subsequent procedures.

IMPORTANT

After this setting is done, do not disturb the Specified Control Setting of the LINE controls until the remaining checks and adjustments are completed.

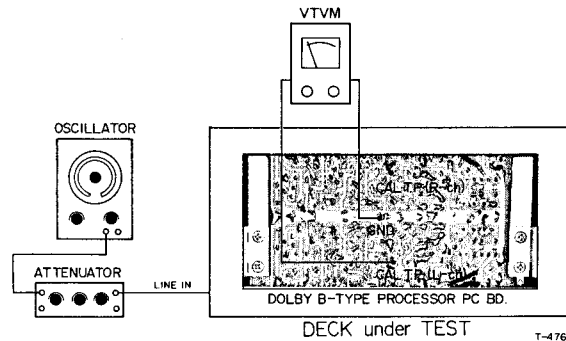

Fig. 7-8 Connection

7-2-3. DOLBY FM/COPY CAL CONTROL SETTING

11. Set the DOLBY FM/COPY switch to IN and apply a 400 Hz signal at -14 dB (154 mV) to the LINE IN jacks.
12. Set the DOLBY FM/COPY-CAL controls on the A-450 rear panel to obtain the reading of 100 mV (-18 dB) on the VTVM.

NOTE

When the DOLBY FM/COPY switch is IN, the LINE and MIC controls have no control over the input signal and only the DOLBY FM/COPY CAL controls (on the back panel) can adjust the input level. However, for the convenience of the following procedure, do not disturb the LINE and MIC control settings.

7-2-4. VUMETER CALIBRATION —RECORD—

13. Set the DOLBY FM/COPY switch to OUT and apply a 400 Hz signal at -5 dB (435 mV)
14. Adjust VR106/206 for $+3$ VU ($\square\square$) on the VU meter.

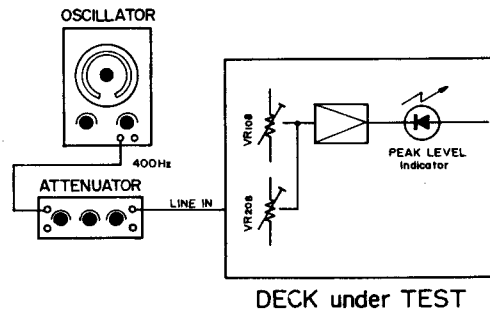

7-2-5. LED PEAK LEVEL INDICATOR CALIBRATION

15. Adjust VR108 so that the PEAK LEVEL indicator lights as shown in Fig. 7-9, when a 400 Hz signal is applied at required level to the left channel LINE IN jack. Keep the right channel LINE IN jack disconnected from an AF oscillator.
16. For the right channel, repeat the above procedure except adjust VR208. Keep the left channel LINE IN jack disconnected from the AF oscillator.
17. After setting both channels, make sure when required signal is simultaneously applied to both channels, the indicator reacts the same as above.

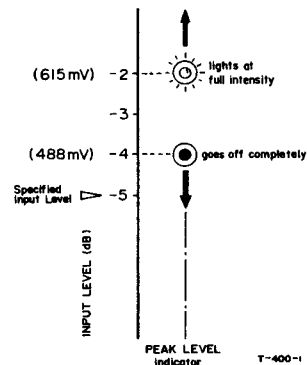

Fig. 7-9 LED Peak Level Indicator Setting

7-2-6. DOLBY NR EFFECT MEASUREMENT

1. Load any recordable tape.
2. Place the deck in the RECORD-PAUSE mode.
3. Apply a 1 kHz signal at proper level.
4. Adjust the Attenuator for 10 mV (-38 dB) on the VTVM. Note this reading for temporary reference level for the following measurements.
5. Set the DOLBY NR switch to IN.
6. Make sure the reading reduces 5 dB \pm 1 dB from the reference level.
7. Reset the DOLBY NR switch to OUT.
8. Repeat the above procedures (steps 3 - 6), with the following exceptions.

Applied test signal: 10 kHz
 Reading on VTVM: 3.2 mV (-48 dB)
 (Reference level)

Variation from reference: 10 dB \pm 1 dB

Specification:

Variation from reference at 1 KHz: 5 dB \pm 1 dB

Variation from reference at 10 KHz: 10 dB \pm 1 dB

7-2-7. DOLBY FM COMPENSATOR EFFICIENCY CHECKS

1. Load any recordable tape.
2. Place the deck in the RECORD-PAUSE mode.
3. Apply a 400 Hz signal at -14 dB (154 mV).
4. Read the VTVM indication.
Note this reading for temporary reference level for the following measurements.
5. Apply a 10 kHz signal at -14 dB.
6. Make sure the reading raises 8 dB \pm 1 dB from the reference level.
7. Set the SOURCE switch to NORMAL.
8. Repeat the above procedures (steps 3 - 5).
9. Make sure the reading of the 10 kHz signal is within \pm 1 dB from temporary reference level of 400 Hz signal.

Specifications:

Variation from reference at FM (SOURCE switch):
 8 dB \pm 1 dB

Variation from reference at NORMAL (SOURCE switch):
 0 dB \pm 1 dB

CONNECTION: See Fig. 7-8

SWITCH & CONTROL SETTING:

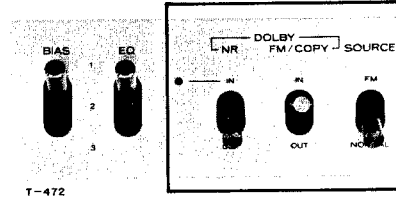

OUTPUT Control: Specified Control Setting (See 7-1-2)
 LINE Control: Specified Control Setting (See 7-2-2)
 MIC Control: Minimum Setting

NOTE

Do not move any control setting above, though these control settings are ineffective in these checks. See 7-2-3 NOTE for details.

CONNECTION

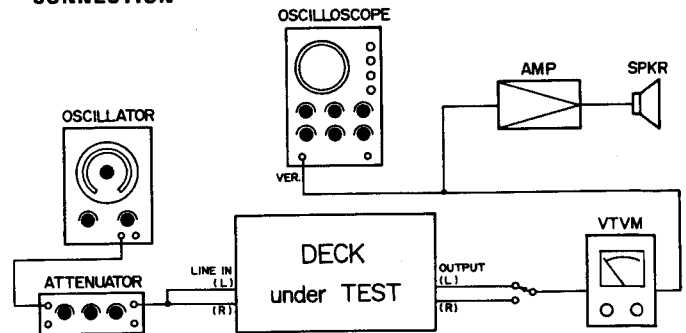
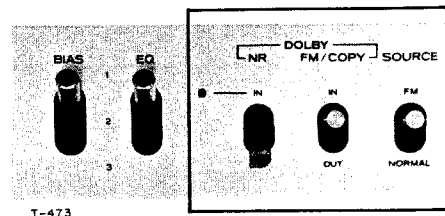

Fig. 7-10 Connection

SWITCH & CONTROL SETTING:



OUTPUT Control: Specified Control Setting (See 7-1-2)
 LINE Control: Specified Control Setting (See 7-2-2)
 MIC Control: Minimum Setting

NOTE

Do not move any control setting above, though these controls settings are ineffective in these checks. See 7-2-3 NOTE for details.

7-3. RECORDING PERFORMANCE

IMPORTANT

Before making any adjustments of the amplifier, be sure that all tests in the playback performance section have been accomplished and that all adjustments are correct. The playback performance should be properly adjusted.

7-3-1. BIAS TRAP ADJUSTMENTS

NOTE

The VTVM used in this procedure must have load impedance of 1 MΩ or more.

1. Load any recordable tape.
2. Place the deck in the RECORD-PAUSE mode with no signal applied.
3. Adjust L102/202 for a minimum reading.

7-3-2. RECORD BIAS SETTING

CrO₂ TAPE

1. Load a TEAC MTT-505TB test tape.
2. Adjust VC-101/201 to minimum (counter clockwise) position.
3. Apply and record a 1 kHz signal at -15 dB (137 mV).
4. Rewind and play this recorded section and note the VTVM indication.
5. Turn VC101/201 clockwise slightly and record another section of tape.
6. Rewind over this section and play the tape again and note the VTVM indication.
7. Repeat this operation of recording, rewinding, playing, and adjusting until the peak value on the VTVM is obtained.
8. Then, adjust VC101/201 slightly further clockwise until the level decreases by 0.5 dB from the peak level.
9. After the above adjustment is done, apply and record two tone signals in turn; a 1 kHz signal and a 10 kHz signal, both at -38 dB (9.75 mV).
10. Adjust VC101/201 slightly until identical values at both frequencies are found using the same process as explained above.

NOTE

After adjusting the bias setting, the output level of the 1 kHz signal must stay finally within the limits (1.5 dB over-bias from the peak) as indicated in the Fig. 7-12.

Fe-Cr TAPE

11. This adjustment is the same as using the method described in the "CrO₂ Tape" with the exceptions of following items.

BIAS/EQ switches: "2" position
 Test tape: MTT-504T
 Adjustments: VC102/202

CONNECTION

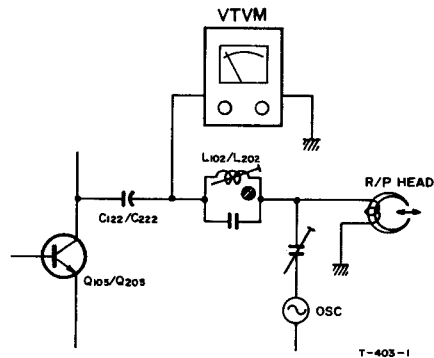
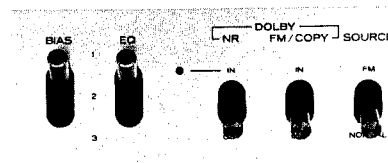

Fig. 7-11 Connection

SWITCH & CONTROL SETTING:



OUTPUT Control: Specified Control Setting (See 7-1-2)
 LINE Control: Specified Control Setting (See 7-2-2)
 MIC Control: Minimum Setting

CONNECTION: See Fig. 7-10

SWITCH & CONTROL SETTING:
 all the same as above section.

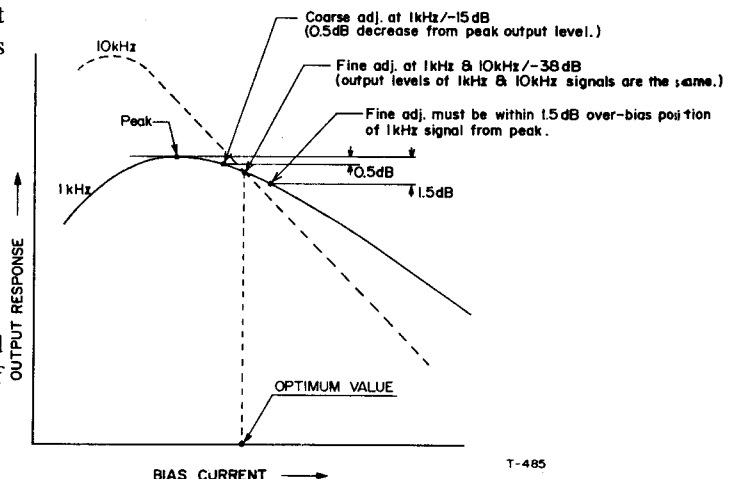

Fig. 7-12 Bias Adjustments (CrO₂ & FeCr tapes)

Hi-Fi TAPE

12. Load a TEAC MTT-501 test tape with the BIAS/EQ switches set to the "3" position and with the DOLBY NR switch set to IN.
13. Apply and record 2 tone signals, in turn; a 400 Hz tone at -38 dB (9.75 mV) and a 10 kHz tone at -38 dB.
14. Rewind and play this recorded section.
15. Compare the differences between the output level of the 400 Hz signal and that of the 10 kHz signal.
16. The output level of the 10 kHz signal must be 4 dB above the 400 Hz signal level.
17. Adjust VC103/203 to achieve this, continuing the process of the recording-rewinding-playing-adjusting.

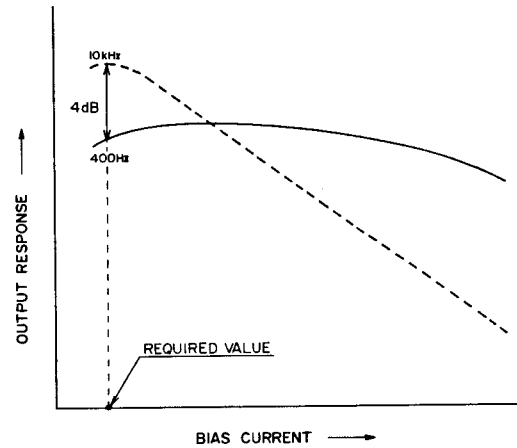

Fig. 7-13 Bias Adjustments (Hi-Fi tape)

7-3-3. RECORD LEVEL SETTING

CrO₂ TAPE

18. Load a TEAC MTT-505TB test tape and set the BIAS/EQ switches to the "1" position.
19. Apply and record a 400 Hz test signal at -5 dB (435 mV).
20. Rewind and play this recorded section.
21. Adjust VR103/203 to obtain -5 dB.
22. Continue the process of the recording-rewinding-playing-adjusting until this -5 dB is obtained.

Fe-Cr TAPE

23. Repeat the above procedure, with the following exceptions.

BIAS/EQ switches: "2" position
 Test tape: MTT-504T
 Adjustments: VR104/204

Hi-Fi TAPE

24. Repeat the above "CrO₂ Tape" procedure, with the following exceptions.

BIAS/EQ switches: "3" position
 Test tape: MTT-501
 Adjustments: VR105/205

7-3-4. DISTORTION CHECKS

CrO₂ TAPE

1. Load a TEAC MTT-505TB test tape.
2. Apply and record a 400 Hz test tone at -8 dB (308 mV).
3. Rewind and play this recorded section.
4. Read the indicated value on the distortion analyzer.

Fe-Cr TAPE

5. Repeat the above procedure, with the following exceptions.

BIAS/EQ switches: "2" position
 Test tape: MTT-504T

Hi-Fi TAPE

6. Repeat the above "CrO₂ Tape" procedure, with the following exceptions.

BIAS/EQ switches: "3" position
 Test tape: MTT-501

CONNECTION

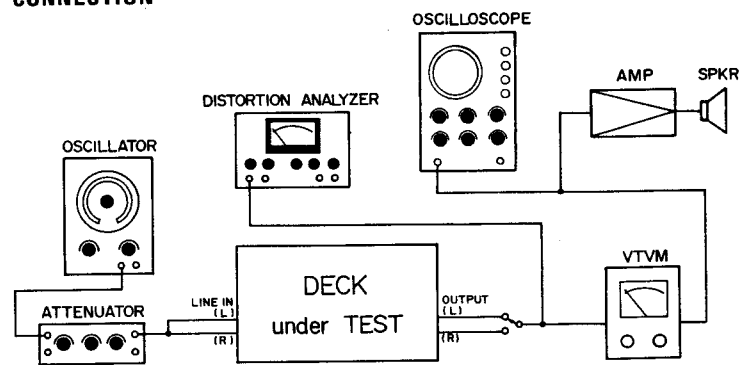
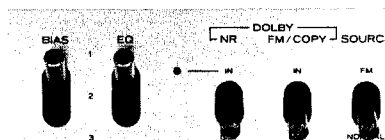

Fig. 7-14 Connection

SWITCH & CONTROL SETTING:



Controls are same as preceding section.

Specification: 2.5% or less (w/ 3 types of tape)

7-3-5. FREQUENCY RESPONSE –OVERALL–

Cr₂ TAPE

1. Load a TEAC MTT-505TB test tape.
2. Apply and record a test signal from 31.5 Hz to 14 kHz at -38 dB (9.75 mV).
3. Rewind and play this recorded section.
4. Make sure the readings on the VTVM are within the response limits.
5. In case of any deviation in the High frequency range of the response limits, clean the heads and if this cleaning is ineffective adjust L103/203.

Fe-Cr TAPE

6. Repeat the above procedure, with the following exceptions.

BIAS/EQ switches: "2" position
 Test tape: MTT-504T
 Adjustments: L105/205

Hi-Fi TAPE

7. Repeat the above "Cr₂ Tape" procedure, with the following exceptions.

BIAS/EQ switches: "3" position
 DOLBY NR switch: IN
 Test tape: MTT-501
 Applied frequencies: 40 Hz ~ 12.5 kHz
 Adjustments: L104/204

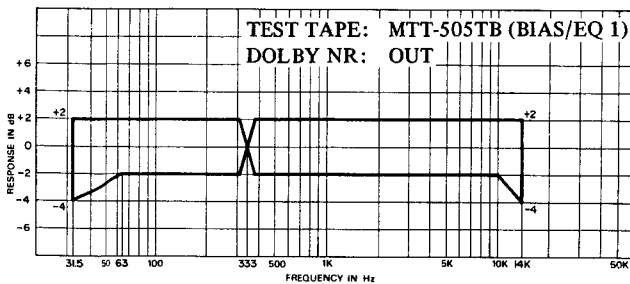
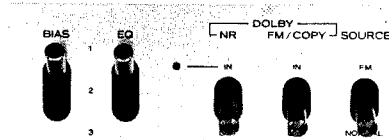

Fig. 7-15 Overall Frequency Response Limits (for BIAS/EQ 1)

CONNECTION: See Fig. 7-10

SWITCH & CONTROL SETTING:



OUTPUT Control: Specified Setting (See 7-1-2)
 LINE Control: Specified Setting (See 7-2-2)
 MIC Control: Minimum Setting

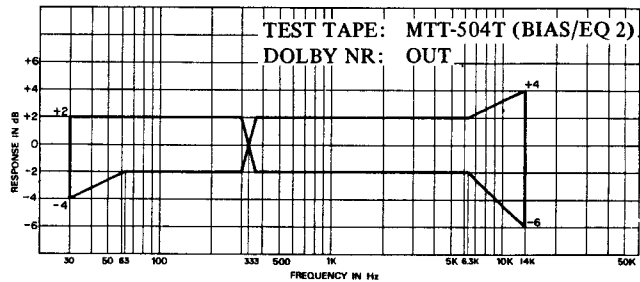

Fig. 7-16 Overall Frequency Response Limits (for BIAS/EQ 2)

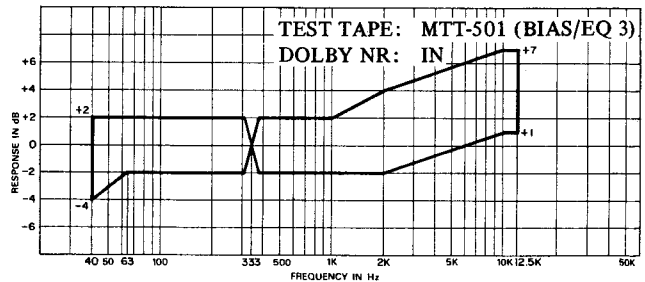

Fig. 7-17 Overall Frequency Response Limits (for BIAS/EQ 3)

7-3-6. SIGNAL TO NOISE RATIO –OVERALL–

Specification:

- Cr₂ tape: 47 dB (minimum)
- FeCr tape: 45 dB (minimum)
- Hi-Fi tape: 45 dB (minimum)

Cr₂ TAPE

1. Load a TEAC MTT-505TB test tape.
2. Place the deck in the record mode for a few seconds with no signal applied.
3. Rewind and play this recorded section.
4. Read the indication on the VTVM.
5. The VTVM should indicate -52 dB minimum (1.94 mV maximum).
6. This -52 dB corresponds to the specified signal-to-noise ratio of 47 dB (minimum): the difference between the residual noise of -52 dB and the specified output level -5 dB (435 mV).

CONNECTION: See Fig. 7-4 (B)

SWITCH & CONTROL SETTING:

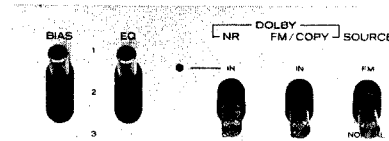

OUTPUT Control: Specified Control Setting (See 7-1-2)
 LINE Control: Specified Control Setting (See 7-2-2)
 MIC Control: Minimum Setting

Fe-Cr TAPE

7. Repeat the above procedure, except use the TEAC MTT-504T test tape and set BIAS/EQ switches to "2" position.
8. The VTVM should indicate -50 dB minimum (2.44 mV maximum).
9. This -50 dB corresponds to the specified signal-to-noise ratio of 45 dB (minimum): the difference between the residual noise of -50 dB and the specified output level -5 dB.

Hi-Fi TAPE

10. Repeat the above "CrO₂ Tape" procedure, except use the TEAC MTT-501 test tape and set BIAS/EQ switches to "3" position.
11. The VTVM should indicate -50 dB minimum.
12. This -50 dB corresponds to the specified signal-to-noise ratio of 45 dB (minimum): the difference between the residual noise of -50 dB and the specified output level -5 dB.

7-3-7. ERASE EFFICIENCY

NOTE

To measure erase efficiency, a 1 kHz narrow bandpass filter should be used. The test signal delivered from the AF oscillator should be tuned to the filter used.

CrO₂ TAPE

1. Load a TEAC MTT-505TB test tape.
2. Apply and record a 1 kHz signal at +5 dB (1.37 V) for several seconds. (1)
3. Rewind the tape to the mid-point of the recording and remove the signal from the LINE IN jacks. (2)
4. Place the deck in the record mode and record through this previously recorded portion with no input signal applied. (3)
5. Rewind the tape to the starting point of the 1 kHz signal recorded portion. (4)
6. Play the tape and read the indication on the VTVM to obtain the output level of both the unerased portion and the erased portion of the recorded section. (5)
7. Measure the output level differences between the 2 portions.

Specification: 65 dB (minimum)

Fe-Cr & Hi-Fi TAPES

The erase efficiency checks for these tapes usually may be omitted unless the technician wants to confirm they also are within specifications.

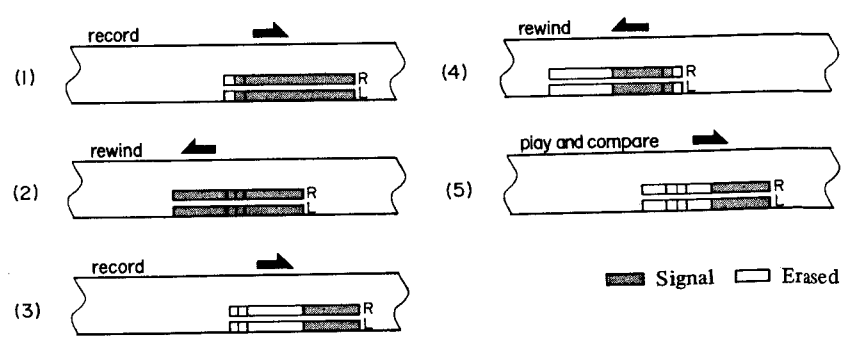
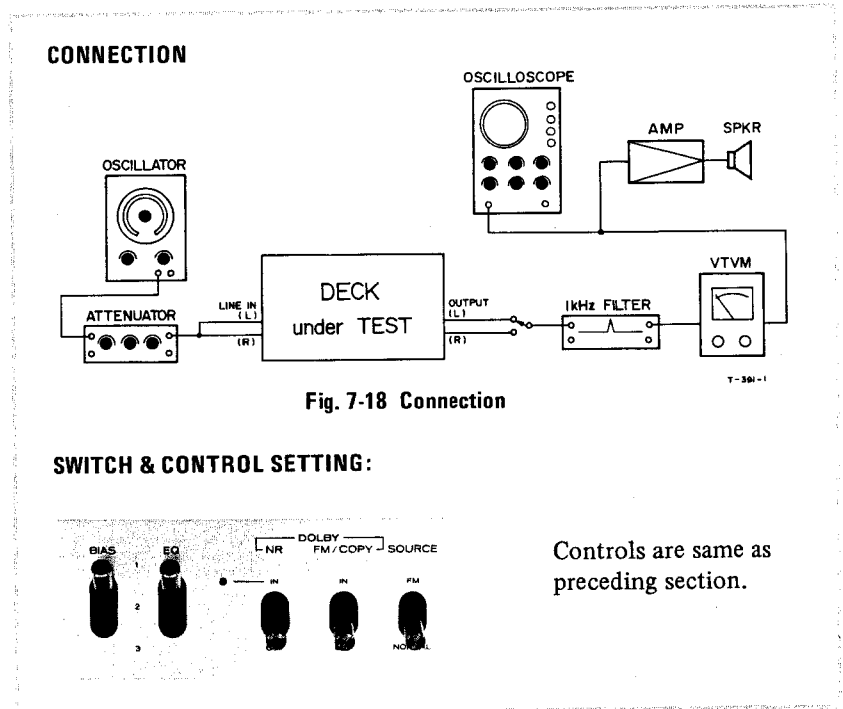

7-3-8. CHANNEL SEPARATION

CrO₂ TAPE

NOTE

To check channel separation (cross talk between channels), a 1 kHz narrow bandpass filter should be used. The test signal delivered from an AF oscillator should be tuned to the filter used.

1. Load a TEAC MTT-505TB test tape.
2. Apply a 1 kHz test tone at -5 dB (435 mV) into the left channel.
3. Place the deck in the record mode for about 30 seconds. (1)
4. Rewind the tape to the starting point of recording. (2)
5. Play the tape and measure the output level differences between the left and right channels. (3)

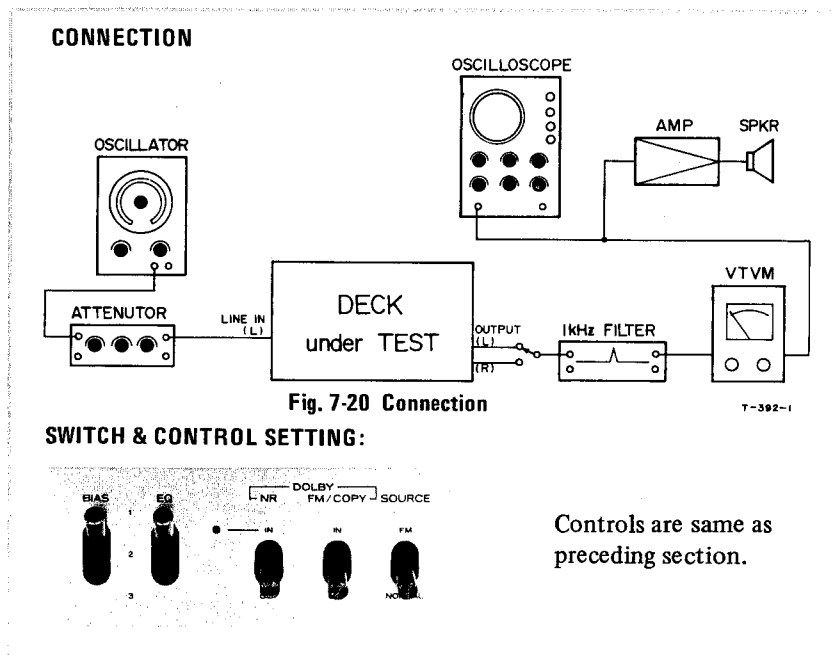

Fe-Cr & Hi-Fi TAPES

The channel separation checks for these tapes usually may be omitted unless the technician wishes to confirm that they also are within specifications.

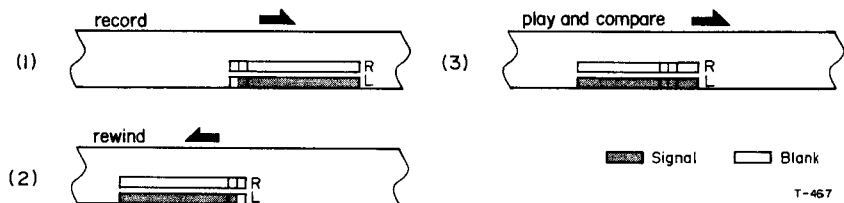

Specification: 30 dB (minimum)

7-3-9. ADJACENT TRACK CROSSTALK MEASUREMENT

CrO₂ TAPE

NOTE

The tape must be completely erased or demagnetized prior to this procedure.

1. Load a TEAC MTT-505TB test tape.
2. Apply a 125 Hz test signal at -5 dB (435 mV).
3. Place the deck in the record mode for about 30 seconds. (1)
4. Rewind the tape to the starting point of recording. (2)
5. Play the tape and measure the output level of the recorded portion. Note this reading for temporary reference level for the following measurements. (3)
6. Remove the test tape, turn it over and replace it in the deck. (4)
7. Play the tape back and read the output level. (5)
8. Get the differences between this reading and the reading previously measured of the 125 Hz signal.

Specification: 40 dB (minimum)

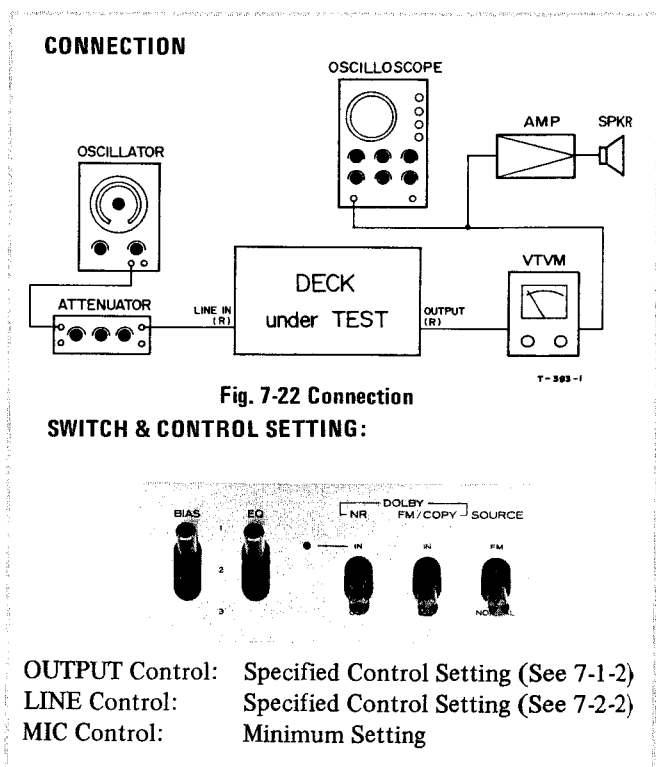

Fe-Cr & Hi-Fi TAPE

9. The crosstalk between adjacent tracks checks for these tapes usually may be omitted unless the technician wishes to confirm that they also are within specifications. (1)

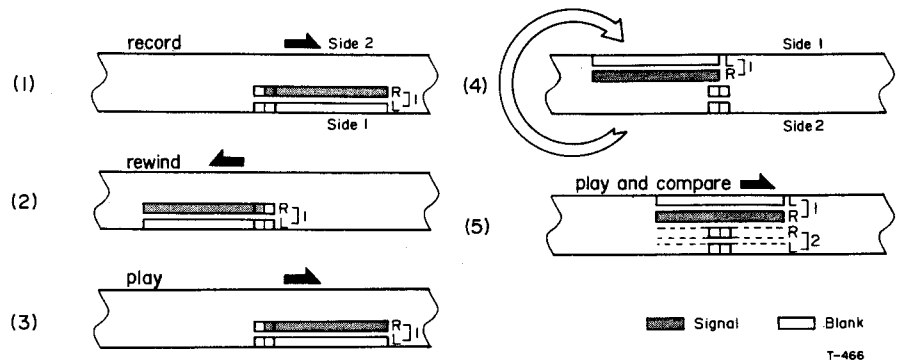

Fig. 7-23 Adjacent Track Crosstalk Measurement Procedure

7-4. ADJUSTMENT LOCATION

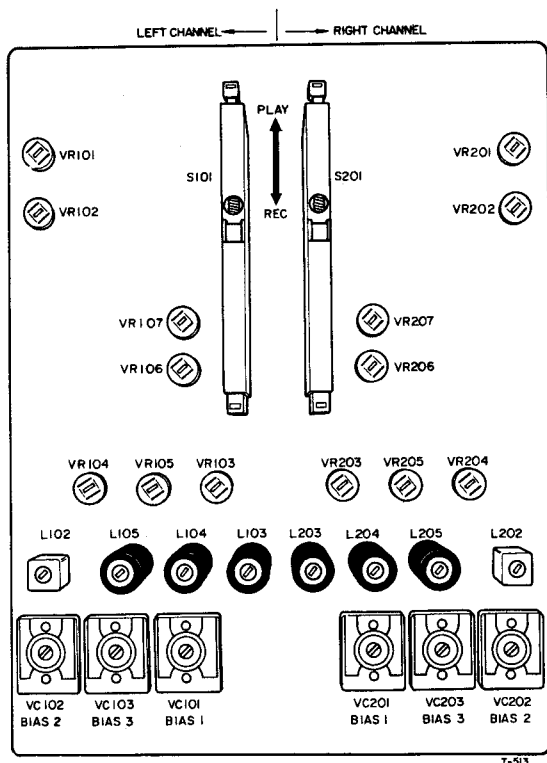
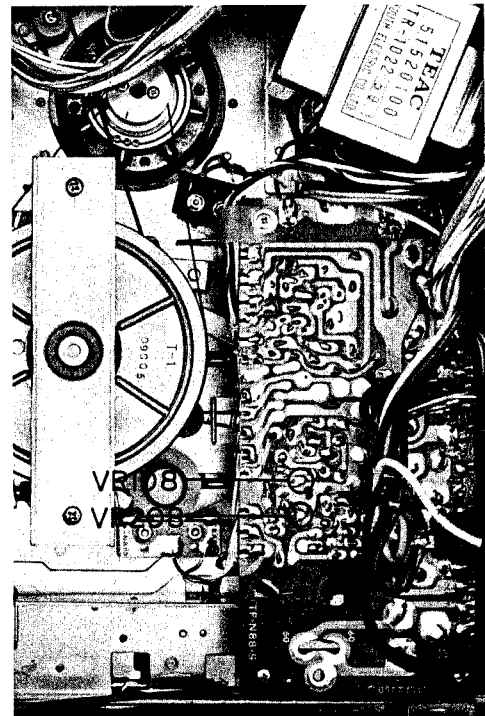

Fig. 7-24 Adjustment Location (on RECORD/PLAYBACK AMPL. PC BD.)



T-516

Fig. 7-25 Adjustment Location (on POWER SUPPLY PC BD.)

VR101/201	Playback EQ	VC101/201	Record bias (1)
VR102/202	Playback level	VC102/202	Record bias (2)
VR103/203	Record level (1)	VC103/203	Record bias (3)
VR104/204	Record level (2)	L102/202	Bias trap
VR105/205	Record level (3)	L103/203	Record EQ (1)
VR106/206	VU meter calibration (Record)	L104/204	Record EQ (3)
VR107/207	VU meter calibration (Playback)	L105/205	Record EQ (2)
VR108/208	Peak level indicator adj.		

8. LEVEL DIAGRAM

PLAYBACK SECTION

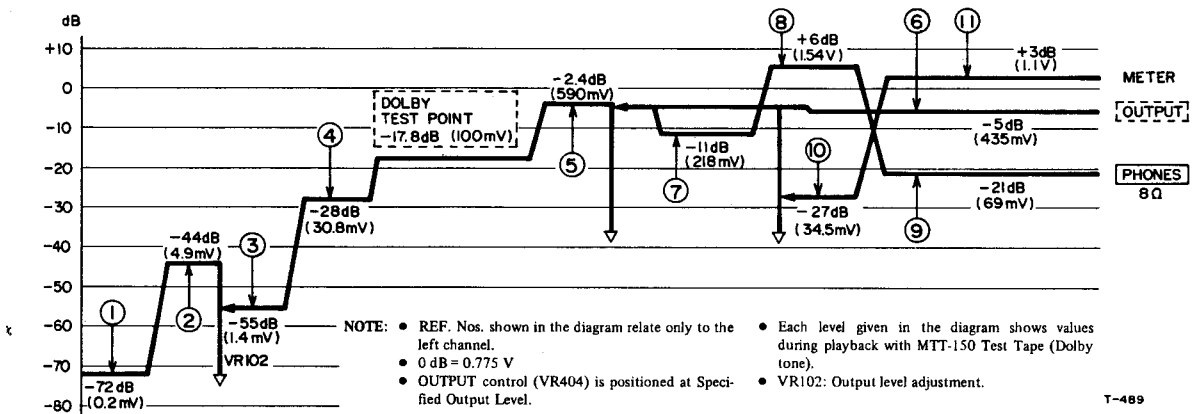
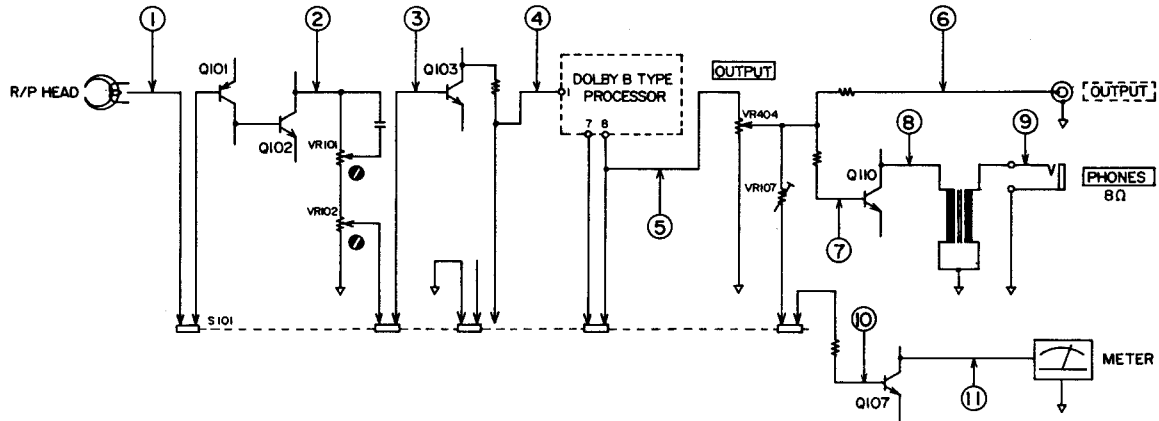

T-489

RECORDING SECTION

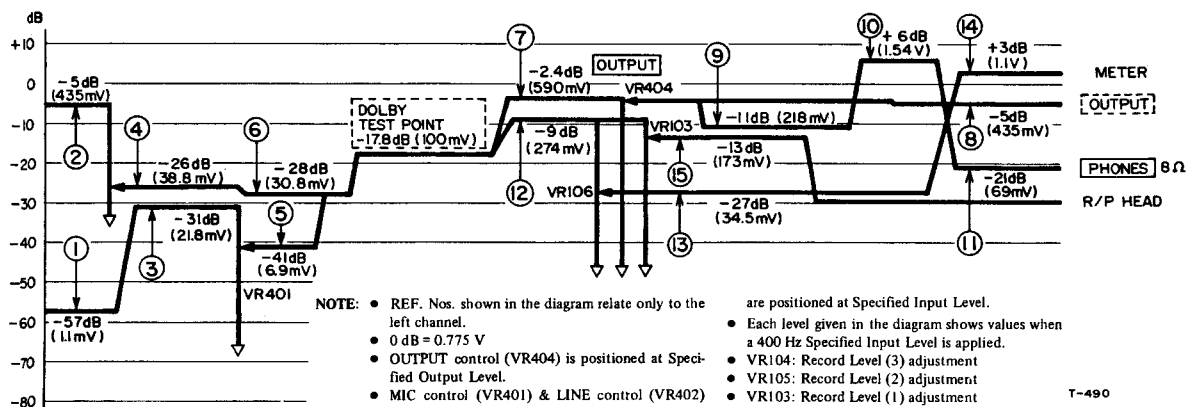
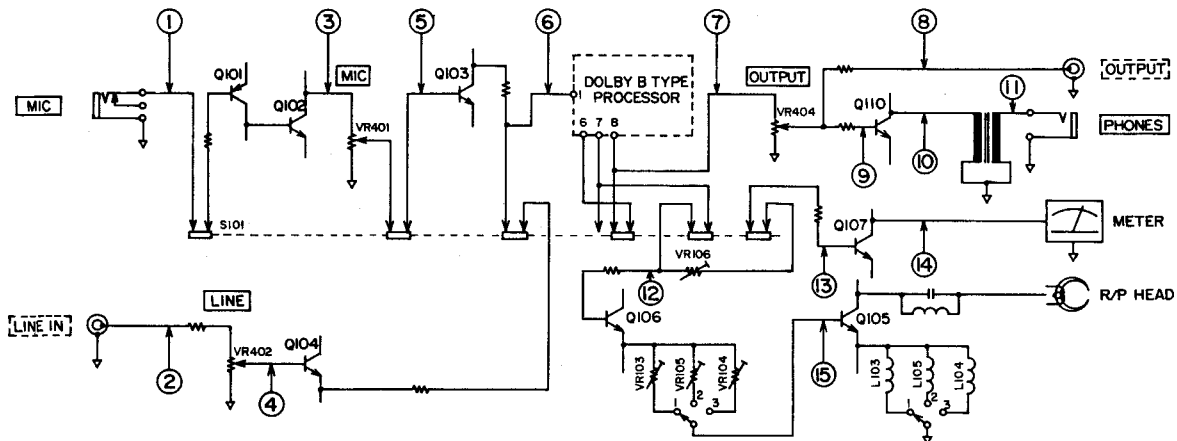

T-490

9. TROUBLE-SHOOTING

NOTE

REF. No's indicated in the following table refer to the left channel, for the right channel REF. No. identification, see schematic diagram.

TAPE TRANSPORT SECTION

1. Fuse blows when POWER is switched ON
 - Defective Power Transformer
2. Auto End-stop will not work in Play and/or Fast Wind. +B voltage not present between terminal A of SCR and GND.
 - Defective Resistor R307
 - Defective Diode D302Solenoid will not energize when SCR terminals A and K are switched ON.
 - Defective Switch S109
 - Defective SolenoidSolenoid will not work when SCR terminals A and G are shorted together.
 - Defective SCR
3. Tape winds onto Capstan Shaft.
 - Defective Pinch Roller
 - Defective Take-up Reel Table Ass'y
 - Idler slipping
 - Tape path wrong (improper Tape Guide position bad Head mounting)
4. Excessive Wow and Flutter
 - Defective Pinch Roller, Pinch Roller pressure incorrect
 - Capstan Belt stretched or oily
5. Capstan does not rotate
 - Capstan Belt off
 - Defective Motor
6. Index Counter will not count
 - Counter reset button not fully depressed.
 - Counter Belt off

AMPLIFIER SECTION

1. No sound in playback mode
Noise (hum or clicking noise) appear when touching head wires.
 - Poor soldering of head terminations
 - Defective HeadSound can be heard during recording
 - Defective Switch S101
 - Defective Transistor Q101, Q102
 - Defective Parts associated with parts indicated aboveSound cannot be heard during recording.
 - Defective Transistor Q101, Q102, Q103
 - Defective Dolby NR Circuit

- Defective Parts associated with parts indicated above
2. Level Meter will not indicate in playback mode.
 - Defective Level Meter
 - Defective Transistor Q107
 - Defective Semi-fixed Resistor VR107
 - Defective Parts associated with parts indicated above
 3. Loss of high frequencies in playback mode
High frequencies too low
 - Defective Transistor Q102
 - Playback equalizer circuit wrongHigh frequencies are several dB below specified response limits
 - Head dirty or defectiveLoss of high frequencies including level variation
 - Improper head-to-tape contact
 - Unstable functioning of tape transport mechanism
 4. Poor playback signal-to-noise ratio
Excessive hum – reduced when changing Power Transformer.
 - Defective Power TransformerExcessive white noise (hiss and circuit noise)
 - Defective Head
 - Defective Transistor Q101, Q102
 - Associated circuitry of Transistor Q101, Q102Wave form varies continuously
 - Defective Transistor Q101, Q102
 - Defective Capacitor C 102, C108
 - Defective Parts associated with parts indicated above
 5. Does not record
Can record when changing Bias Switch setting
 - Defective Bias Switch
 - Defective Trimmer Capacitors VC101, VC102, VC103
 - Defective Parts associated with parts indicated aboveCannot erase, also
 - Bias Oscillator Ass'y faultyCan erase – sound from record monitor mode is normal
 - Head dirty
 - Defective Transistor Q105, Q106
 - Defective Switch S101
 - Defective Circuitry of Q105, Q106

10. MODEL DIFFERENCES COMPARISON CHART BETWEEN U.S.A./CANADA MODELS & OTHER AREA MODELS

There are several differences between U.S.A./CANADA models and models distributed in other areas. They are indicated in the following table.

10-1. FUNCTIONAL DIFFERENCE TABLE

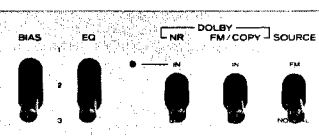
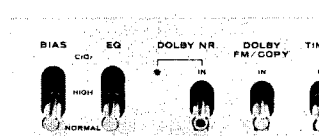
Item	Models	U.S.A./CANADA	All except U.S.A./CANADA	Remarks
1. Switch Construction		 (See the Remarks.)		Meaning of BIAS/EQ switch nos on U.S.A./CANADA models: 1: For CrO ₂ tape 2: For FeCr tape 3: For Regular Hi-Fi tape
2. AC Outlet Socket		Not provided	Provided	Installed on Back Panel
3. Fuse for AC Outlet		Not provided	Provided	
4. Dolby FM Compensator Circuit		Provided	Not provided	
5. A 19 kHz Filter Switch		Provided (See the Remarks.)	Not provided	This Switch functions together with SOURCE Switch. When SOURCE Switch is at FM position, the Filter circuit is also activated.

10-2. ELECTRICAL ALIGNMENT SECTION (FOR ALL EXCEPT U.S.A./CANADA MODELS)

There are BIAS and EQ Switch differences between U.S.A./CANADA models and those distributed in other areas as shown in the table on the right.

Electrical alignments on U.S.A./CANADA models, however, are nearly all applicable to models distributed in other areas with the following exception:

BIAS and EQ Switch Comparison Chart

Switch Setting Position	Indication	
	U.S.A./CANADA	All ex. U.S.A./CANADA
Upper	1 (CrO ₂)	CrO ₂
Medium	2 (FeCr)	* HIGH
Lower	3 (*HIGH)	* NORMAL

* HIGH refers to Low noise, high output tape; NORMAL, regular tape

a. ADJUSTMENT LOCATION

For U.S.A./CANADA models, refer to Fig. 7-24 on page 27.

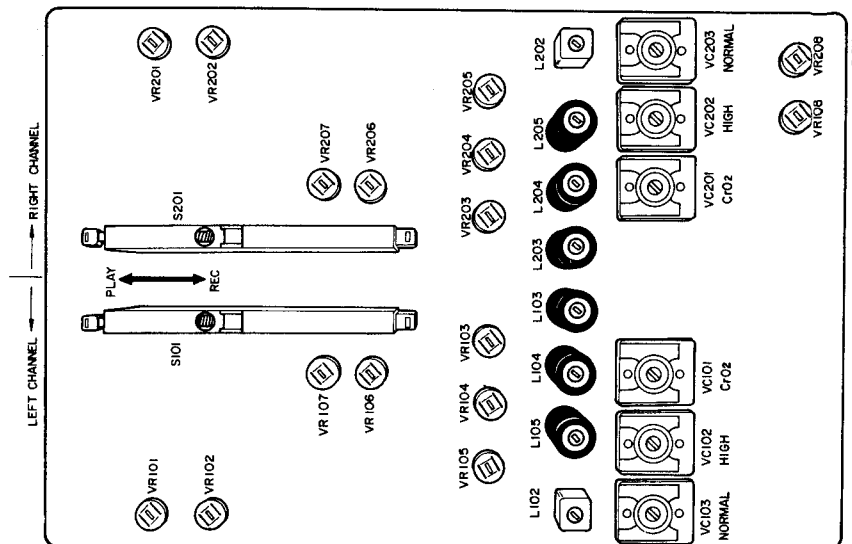
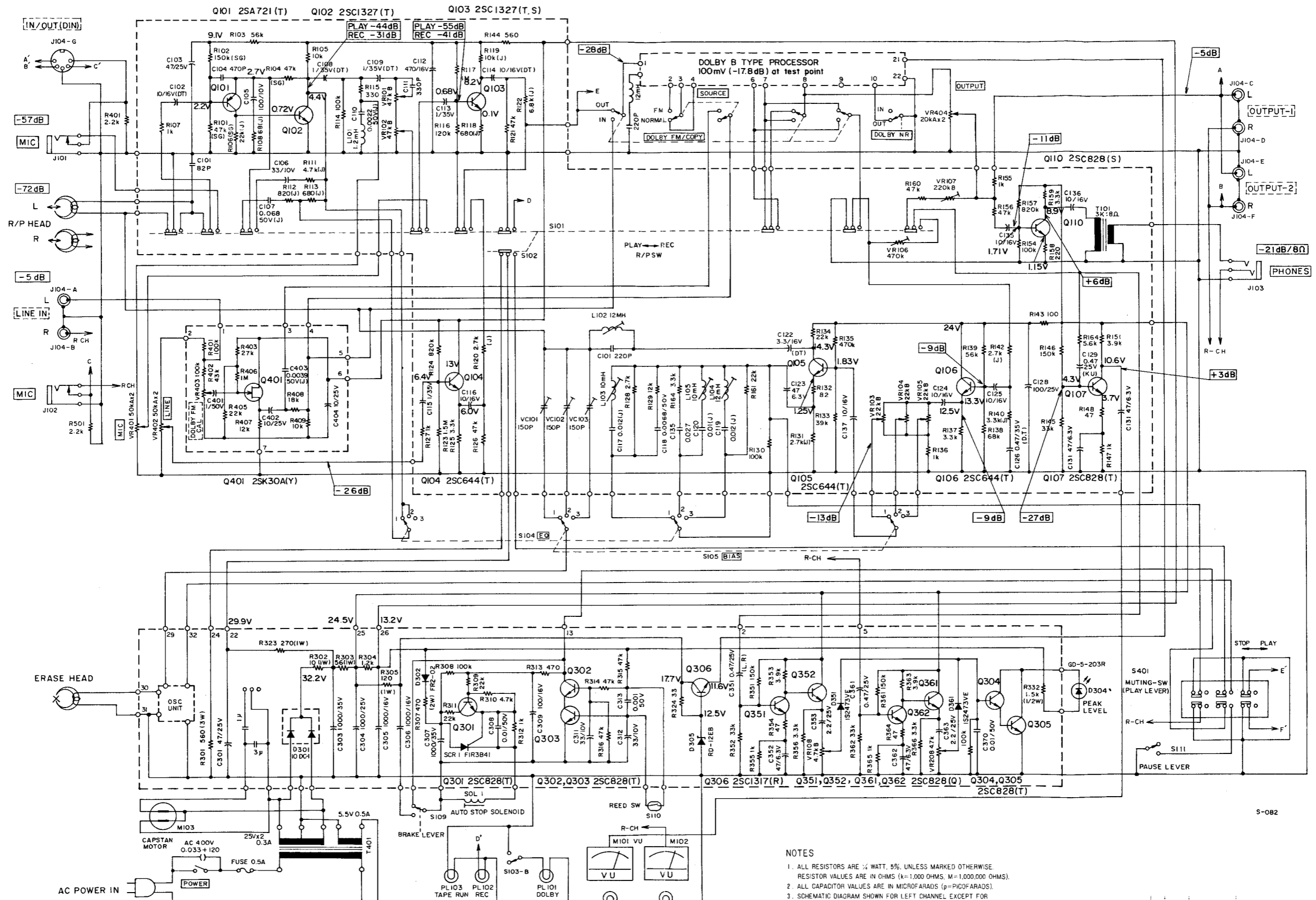

Fig. 10-1 Adjustment Location (on REC/PLAY AMPL. PC BD.)



- NOTES
1. ALL RESISTORS ARE 1/4 WATT, 5%, UNLESS MARKED OTHERWISE. RESISTOR VALUES ARE IN OHMS (k=1,000 OHMS, M=1,000,000 OHMS).
 2. ALL CAPACITOR VALUES ARE IN MICROFARADS (p=PICOFARADS).
 3. SCHEMATIC DIAGRAM SHOWN FOR LEFT CHANNEL EXCEPT FOR SOME OF THE COMPONENTS.
 4. DC VOLTAGES WERE MEASURED DURING PLAY MODE.
 5. SIGNAL LEVELS (dB) WERE MEASURED WITH INPUT AND OUTPUT CONTROLS AT SPECIFIED POSITION.
 6. READING IN dB REFERENCED TO 0dB=0.775V.

6			
5			
4			
3			
2			
1	12-75	CH-201	
REVISION	DATE	CHANGE NO.	

STEREO CASSETTE DECK
 MODEL NO. A-450
 SHEET NO. 2
 TEAC CORPORATION

SIMPLIFIED CIRCUIT DIAGRAM

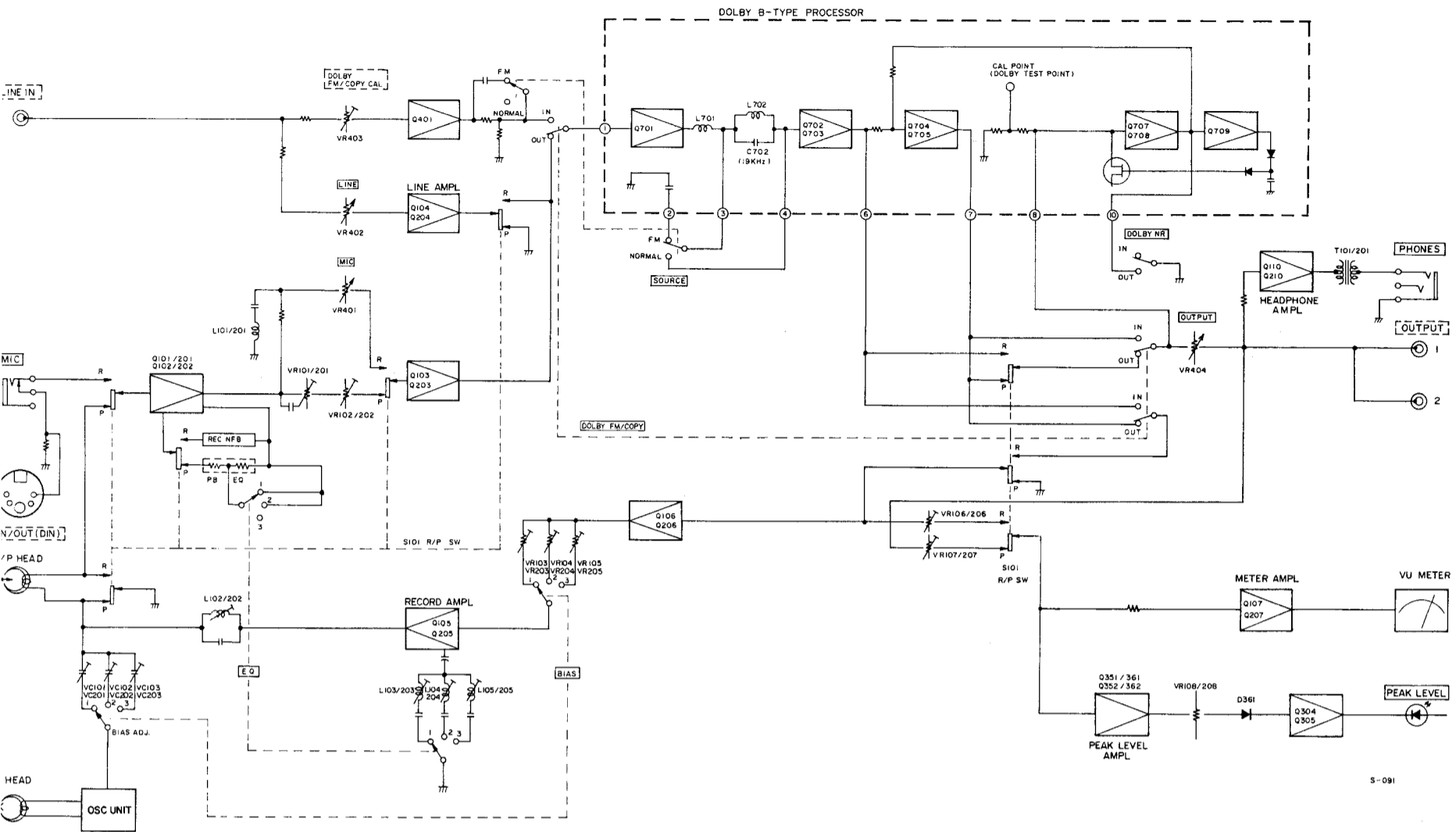

S-091

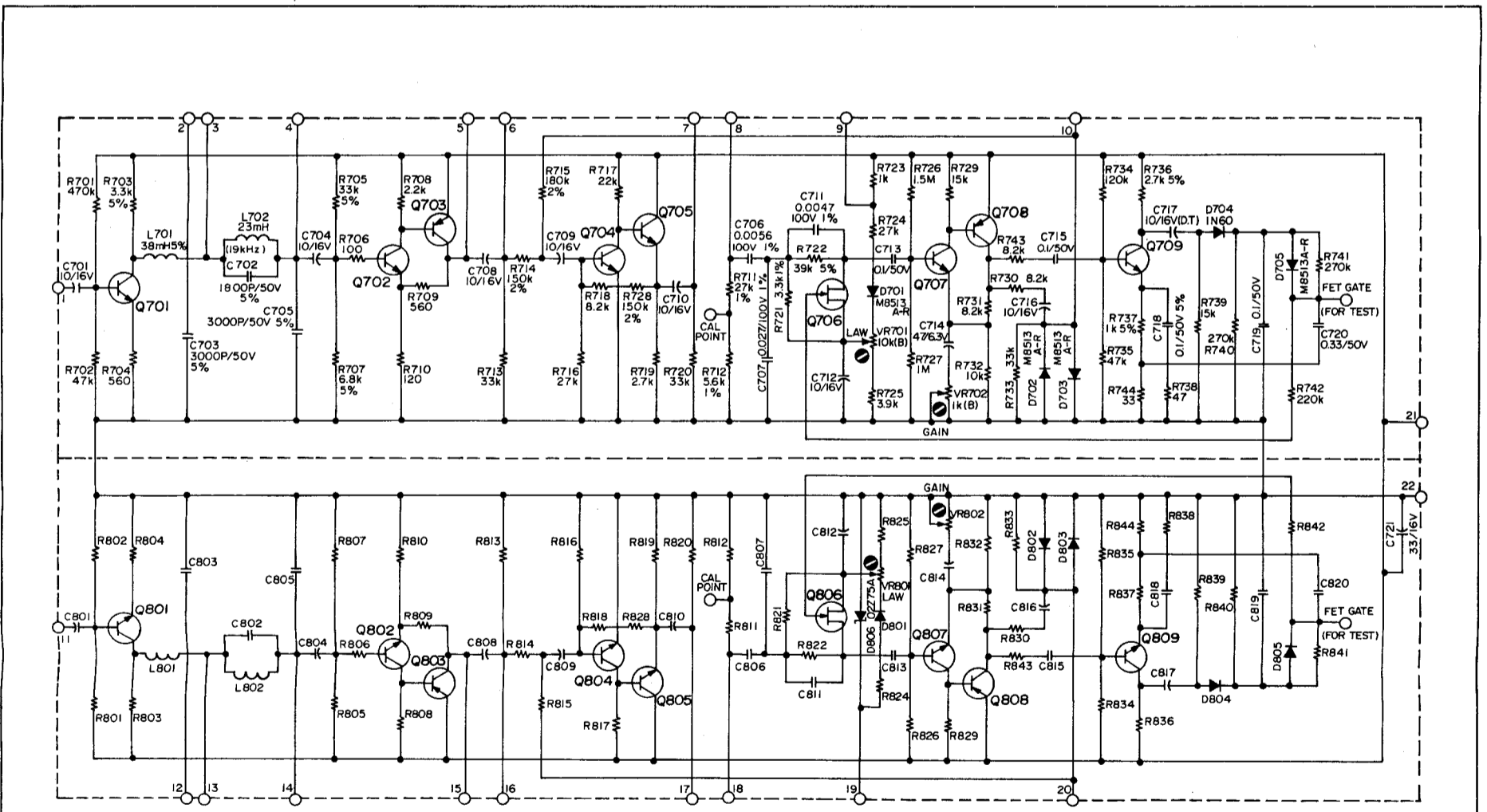

S-083

CIRCUIT REF. NO.	DESCRIPTION	CIRCUIT REF. NO.	DESCRIPTION
Q701 / Q801	2SC1327(T)	Q706 / Q806	2SK30(DA) or 2SK30(DB)
Q702 / Q802	2SC644(S)	Q707 / Q807	2SC1327(T)
Q703 / Q803	2SA666(IS)	Q708 / Q808	2SA666(IS)
Q704 / Q804	2SC644(T)	Q709 / Q809	2SC644(T)
Q705 / Q805	2SC644(S)		

NOTE

- ALL RESISTORS ARE 1/4 WATT, 5%, UNLESS MARKED OTHERWISE. RESISTOR VALUES ARE IN OHMS (k=1000, M=1,000,000).
- ALL CAPACITOR VALUES ARE IN MICROFARADS (p=PICO-FARADS).

REVISION	DATE	CHANGE NO.
6		
5		
4		
3		
2	03-76	
1	12-75	

DOLBY NR
 MODEL NO. A-450 SHEET NO. 1
TEAC CORPORATION

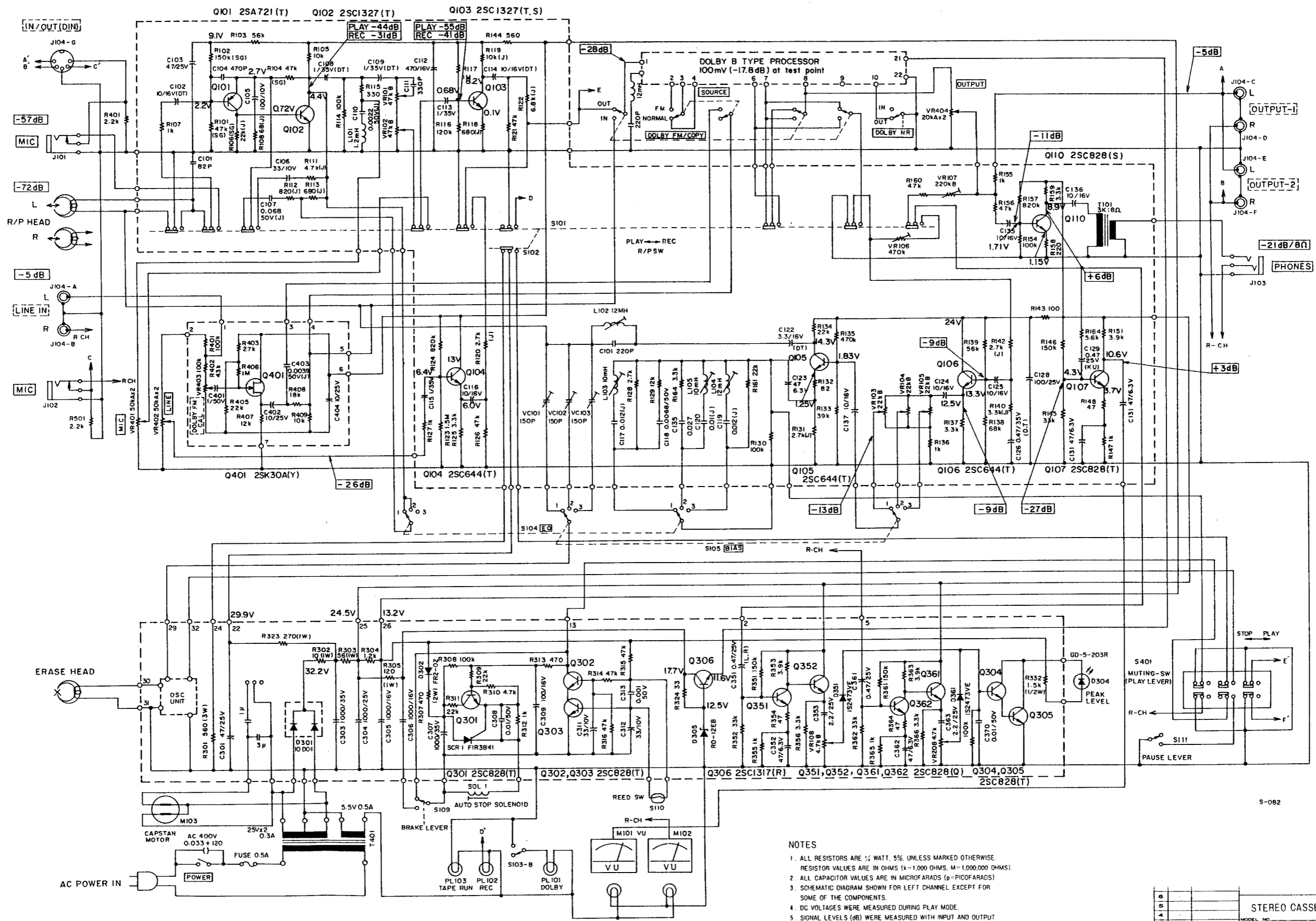

- NOTES
1. ALL RESISTORS ARE 1/4 WATT, 5%, UNLESS MARKED OTHERWISE. RESISTOR VALUES ARE IN OHMS (k=1,000 OHMS, M=1,000,000 OHMS).
 2. ALL CAPACITOR VALUES ARE IN MICROFARADS (p=PICOFARADS).
 3. SCHEMATIC DIAGRAM SHOWN FOR LEFT CHANNEL EXCEPT FOR SOME OF THE COMPONENTS.
 4. DC VOLTAGES WERE MEASURED DURING PLAY MODE.
 5. SIGNAL LEVELS (dB) WERE MEASURED WITH INPUT AND OUTPUT CONTROLS AT SPECIFIED POSITION.
 6. READING IN dB REFERENCED TO 0dB=0.775V.

REVISION	DATE	CHANGE NO.
1	12 75	CH-201

STEREO CASSETTE DECK
 MODEL NO. A-450
 SHEET 05
 TEAC CORPORATION

S-082

SIMPLIFIED CIRCUIT DIAGRAM

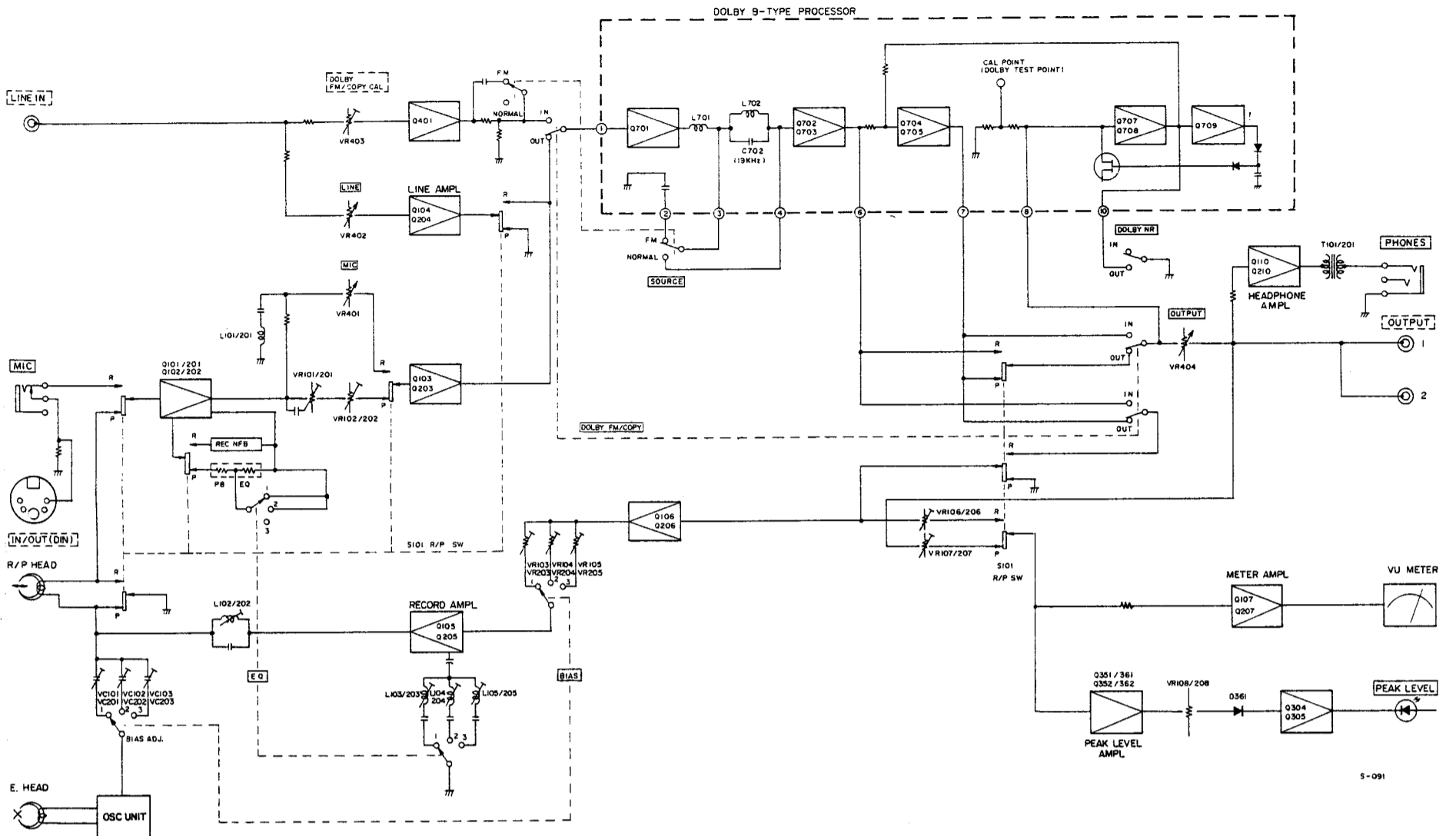

Q01 25A721(T) Q102 25C1327(T) Q103 25C1327(T,S)
 Q104 25A721(T) Q105 25C1327(T) Q106 25C1327(T,S)
 Q107 25A721(T) Q108 25C1327(T) Q109 25C1327(T,S)

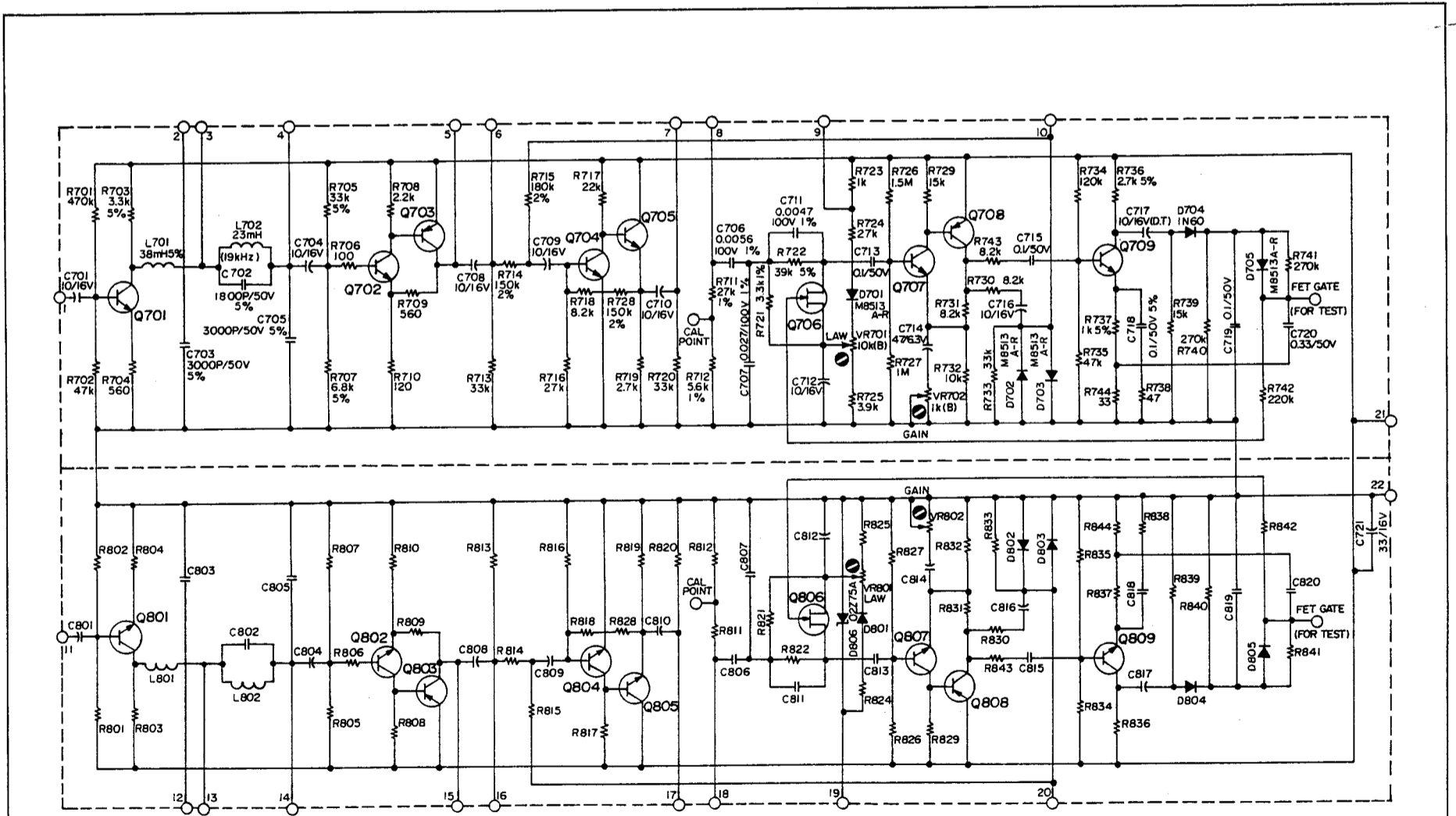

CIRCUIT REF. NO.	DESCRIPTION	CIRCUIT REF. NO.	DESCRIPTION
Q701 / Q801	25C1327(T)	Q706 / Q806	25K30(DA) or 25K30(DB)
Q702 / Q802	25C644(S)	Q707 / Q807	25C1327(T)
Q703 / Q803	25A666(1S)	Q708 / Q808	25A666(1S)
Q704 / Q804	25C644(T)	Q709 / Q809	25C644(T)
Q705 / Q805	25C644(S)		

- NOTE**
- ALL RESISTORS ARE 1/4 WATT, 5%, UNLESS MARKED OTHERWISE. RESISTOR VALUES ARE IN OHMS (k=1000, M=1,000,000).
 - ALL CAPACITOR VALUES ARE IN MICROFARADS (p=PICO-FARADS).

6			
5			
4			
3			
2	03.76		
1	12.75		

DOLBY NR
 MODEL NO. A-450 SHEET NO.
TEAC CORPORATION

S-083

A-450 ELECTRICAL CHECKS AND ADJUSTMENTS

0 dB = 0.775 V

STEP NO.	ITEM	SWITCH/CONTROL SETTING						INPUT SOURCE SIGNAL	OTHER CONDITIONS OR OPERATION	ADJUSTMENT ON DECK	SPECIFICATION	REMARKS
		CONN. DIAG.	BIAS EQ	DOLBY NR	DOLBY FM/COPY	SOURCE	CONTROLS					
I. PLAYBACK PERFORMANCE		Test tape: MTT-150: For Dolby Level Calibration MTT-116K: For Frequency response test for EQ 1 & 2 MTT-116U: For Frequency response test for EQ 3										
1-1	R/P Head Azimuth Adjustments	1	A	3	OUT	OUT	MTT-150	Ensure phase relationship between L-ch & R-ch.	Azimuth adj. nut of head	Phase 45° on oscilloscope	Phase relationship check	
		2					MTT-116U, 10 kHz section			Maximum		
1-2	Specified Output Level Setting	1	B						VR102/202	100 mV (-18 dB) at Dolby T.P.	Maximum output Level	
		2							-	-3.5 dB ± 1 dB (461 mV ~ 580 mV)		
		3	C				MTT-150	OUTPUT: Set to get specified OUTPUT indicated in specification column.		-5 dB (435 mV)	Specified Output Level	
1-3	VU Meter Calibration - Playback -						MTT-150	OUTPUT: Specified setting	VR107/207	+3 VU (□) on VU meter	After calibrating, ensure VU meter indication is same, when DOLBY NR switch is set to IN.	
1-4	Frequency Response - Playback -	1					MTT-116U, 40 Hz ~ 14 kHz section		VR101/201	See Frequency Response Limits on page 18 in the manual.	VR101/201 are only for high frequency spectrum adjustment. For Hi-Fi tape.	
		2		1 & 2			MTT-116K, 40 Hz ~ 14 kHz section				For CrO ₂ & Fe-Cr tapes.	
1-5	Signal to Noise Ratio Checks - Playback -			3			MTT-150	PLAY-PAUSE mode		-52 dB min., or 1.94 mV max. (Corresponds to S/N ratio of 47 dB min.)	Measure OUTPUT level of noise signal and compare this to standard OUTPUT level of -5 dB.	
1-6	Headphone Output Level Checks		D				MTT-150			-21 dB ± 2 dB (54.8 mV ~ 86 mV)	Load imp.: 8 ohm	
II. MONITOR PERFORMANCE		Test tape: Any recordable tape										
		RECORD-PAUSE mode										
												NOTE: * means see REMARKS column.
2-1	Minimum Input Level Checks	1					OUTPUT: Specified Setting LINE: Minimum MIC: Maximum	400 Hz/-67 dB ± 2 dB (274 μV ~ 435 μV)	Check by applying test signal to MIC jacks.		For MIC jacks	
		2	E				OUTPUT: Specified Setting LINE: Maximum MIC: Minimum	400 Hz/-35 dB ± 2 dB (10.9 mV ~ 17.3 mV)	Check by applying test signal to input terminals of DIN Connector.		100 mV (-18 dB) at Dolby T.P.	
		3					OUTPUT: Specified Setting LINE: Maximum MIC: Minimum	400 Hz/-15 dB ± 2 dB (109 mV ~ 173 mV)	Check by applying test signal to LINE IN jacks.		For LINE IN jacks	
2-2	Specified LINE Control Setting		E*				OUTPUT: Specified Setting LINE: Set controls to get specified OUTPUT MIC: Minimum	400 Hz/-5 dB (435 mV)	Set LINE controls for specification.		100 mV (-18 dB) at Dolby T.P.	* Use LINE IN jack • Input level of -5 dB: Specified Input Level for LINE
2-3	DOLBY FM/COPY CAL Control Setting		E				OUTPUT: Specified Setting LINE: Specified Setting MIC: Minimum	400 Hz/-14 dB (154 mV)		DOLBY FM COPY-CAL controls	100 mV (-18 dB) at Dolby T.P.	• LINE & MIC control setting do not affect level. • Input level of -14 dB: Specified Input level for DOLBY FM/COPY
2-4	VU Meter Calibration - Record -		F					400 Hz/-5 dB (435 mV)		VR106/206	+3VU (□) on VU meter	
2-5	LED Peak Level Indicator Calibration		F					400 Hz/-2 dB (615 mV) & 400 Hz/-4 dB (488 mV)		VR108/208	PEAK Indicator Lights at full intensity when input is -2 dB and goes off completely when input is -4 dB	
2-6	Dolby NR Effect Measurement	1						1 kHz Set as necessary for specified output level	Adjust Attenuator for specification.		10 mV (-38 dB) at Dolby T.P.	* Use LINE IN jack • LINE & MIC control setting is ineffective. • 10 mV of specification is reference level for next step.
		2	E*						Ensure VTVM reading reduces to specification from reference level when Dolby NR switch is switched from OUT to IN.		(Variation at 1 kHz) 5 dB ± 1 dB	
		3						10 kHz Set as necessary for spe-	Adjust Attenuator for specification.		3.2 mV (-48 dB) at Dolby T.P.	• 3.2 mV of specification is reference level for next test.

CONNECTIONS

A

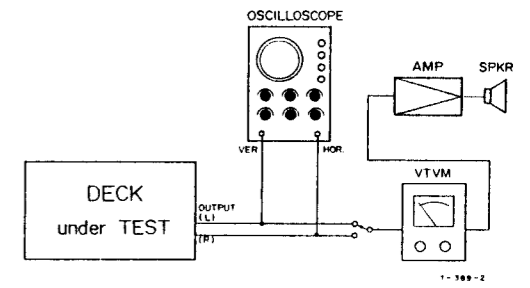

B

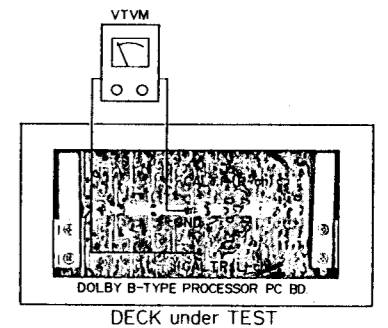

C

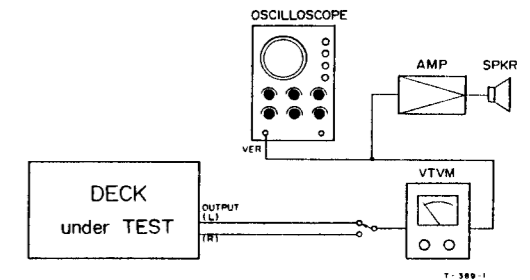

D

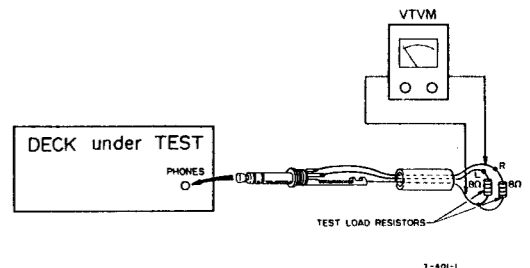

E

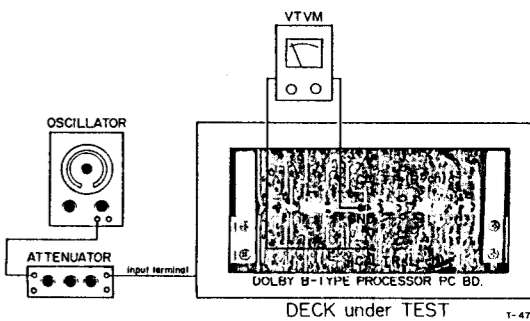

F

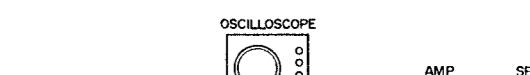

2-6	Dolby NR Effect Measurement	2	E*	-	-	IN	↓	↓		Ensure VTVM reading reduces to specification from reference level when Dolby NR switch is switched from OUT to IN.	(Variation at 1 kHz) 5 dB±1 dB	
		3		-	-	OUT	↓	↓	10 kHz Set as necessary for specified output level	Adjust Attenuator for specification.	3.2 mV (-48 dB) at Dolby T.P.	• 3.2 mV of specification is reference level for next test.
		4		-	-	IN	↓	↓		Ensure VTVM reading reduces to specification from reference level.	Variation at 10 kHz: 10 dB±1 dB	
2-7	Dolby FM Compensator Efficiency Checks	1		-	-	OUT	↓	FM	400 Hz/-14 dB (154 mV)	Note VTVM reading for reference level for next test.		
		2		-	-	↓	↓	↓	10 kHz/-14 dB	Ensure VTVM reading raises to specification from reference level when input signal frequency is changed.	Variation with SOURCE at FM position: 8 dB±1 dB	LINE & MIC control setting is ineffective.
		3	F	-	-	↓	↓	NOR.	400 Hz/-14 dB	Note VTVM reading for reference level for next test.		
		4		-	-	↓	↓	↓	10 kHz/-14 dB	Ensure VTVM reading differs within specification from reference level.	Variation with SOURCE switch set to NORMAL: (0 dB±1 dB)	

III. RECORDING PERFORMANCE

Test tape: MTT-505TB: For BIAS 1/EQ 1 (CrO₂)
 MTT-504T: For BIAS 2/EQ 2 (Fe-Cr)
 MTT-501: For BIAS 3/EQ 3 (Hi-Fi)

NOTE: * means see REMARKS column.

3-1	Bias Trap Adjustments	G	-	-	OUT	OUT	NORMAL	OUTPUT: Specified setting LINE: Specified setting MIC: Minimum	No signal applied	Adjust with REC-PAUSE mode using any recordable tape.	L102/202	Minimum output	
3-2	Record Bias Setting	1							1 kHz/-15 dB (137 mV) Alternately 1 kHz/-38 dB (9.75 mV) & 10 kHz/-38 dB	Coarse adjustment		0.5 dB over bias	
		2		1	1					Fine adjustment	VC101/201	Equal value at both frequencies	
		3							1 kHz/-15 dB (137 mV) Alternately 1 kHz/-38 dB (9.75 mV) & 10 kHz/-38 dB	Coarse adjustment		0.5 dB over bias	
		4	F	2	2					Fine adjustment	VC102/202	Equal value at both frequencies	
		5		3	3	IN						VC103/203	10 kHz output should be 4 dB above 400 Hz.
3-3	Record Level Setting	1		1	1						VR103/203		
		2	F	2	2	OUT	↓	↓			VR104/204	-5 dB (435 mV)	
		3		3	3						VR105/205		
3-4	Distortion Checks	1		1	1								
		2	H	2	2	↓	↓	↓				2.5% or less on Distortion Analyzer	
		3		3	3								
3-5	Frequency Response - Overall -	1		1	1						L103/203	See Frequency Response Limits on page 24 in the manual.	
		2	F	2	2	↓	↓	↓			L105/205		
		3		3	3	IN					L104/204		
3-6	Signal to Noise Ratio - Overall -	1		1	1							-52 dB min. (1.94 mV) (Corresponds to S/N ratio of 47 dB min.)	
		2		2	2							-50 dB min. (2.44 mV) (45 dB min.)	
		3	C	3	3	OUT	↓	↓					
3-7	Erase Efficiency	I	1	1	↓	↓	↓					65 dB min.	Ordinarily measurements for BIAS/EQ "2 & 3" are not necessary.
3-8	Channel Separation	I*	↓	↓	↓	↓	↓					30 dB min.	* Do not connect LINE IN - (R).
3-9	Adjacent Track Crosstalk Measurement	J	↓	↓	↓	↓	↓					40 dB min.	Tape must be completely erased or demagnetized prior to this procedure.

F

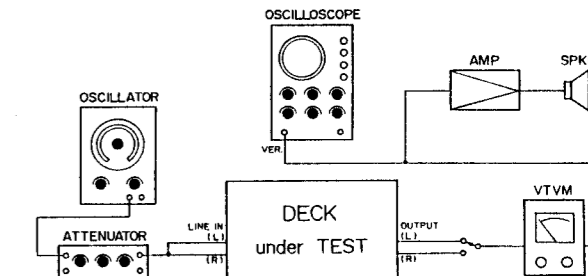

G

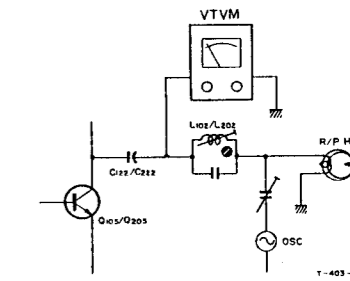

H

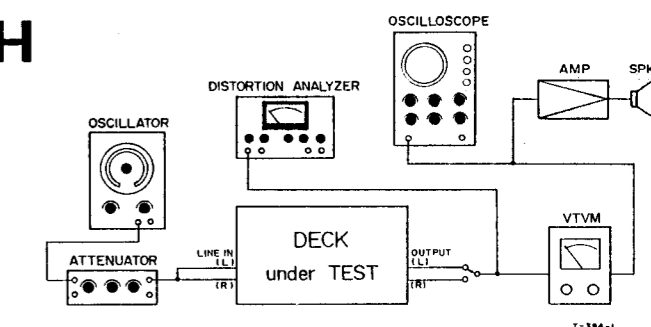

I

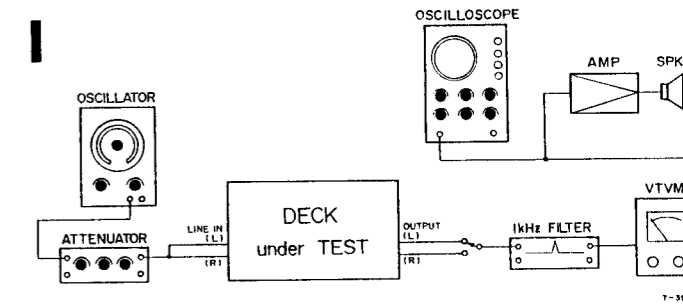

J

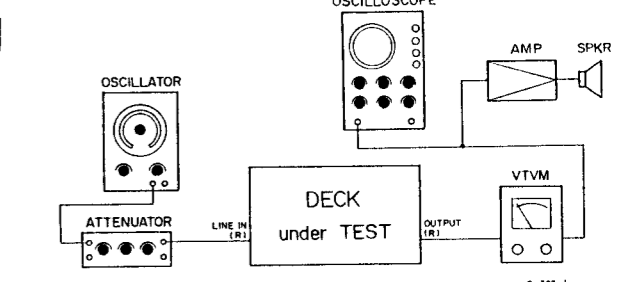

b. BIAS ADJUSTMENTS

All deck can be tested using the procedures stated on page 22, "CrO₂ TAPE" in 7-3-2 using the following additional information as applicable.

BIAS/EQ Switch Setting	TEAC Test Tape	Adjustments
CrO ₂	MTT-505TB	VC101/201
HIGH	MTT-501	VC102/202
NORMAL	MTT-502R	VC103/203

c. FREQUENCY SPECTRUM DIAGRAMS

Frequency Response limits other than the subsequent 2 graphs are the same as ones for U.S.A./CANADA decks.

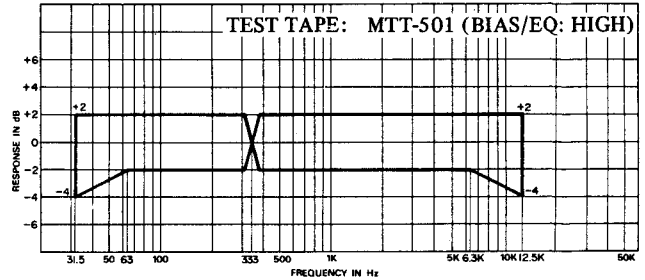

Fig. 10-2 Overall Frequency Response Limits (for BIAS/EQ: HIGH)

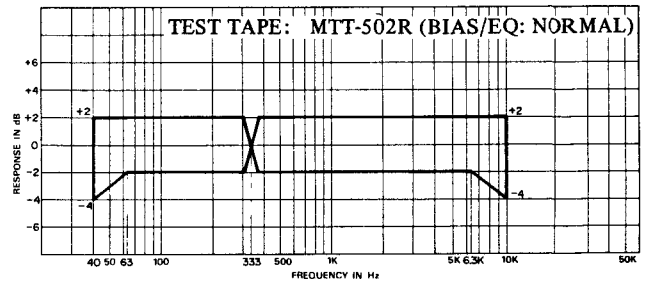

Fig. 10-3 Overall Frequency Response Limits (for BIAS/EQ: NORMAL)

10-3. FREQUENCY & VOLTAGE CONVERSION

a. FREQUENCY CONVERSION PROCEDURE (FOR ALL EXCEPT U.S.A./CANADA MODELS)

1. Disconnect the AC Power Cord and remove all audio cables.
2. Remove the Bottom Cover, release the Drive Belt.
3. Take off the 2 screws from the Motor Pulley and invert the Motor Pulley. (Small diameter on top for 60 Hz, large for 50 Hz.)
4. Re-install the Belt on the pulley (top section) and verify that the Belt is not riding on the lips of the pulleys.
5. Reinstall the screws.
6. Rotate the Flywheel several turns to check for proper seating.
7. The Frequency Selector Bar on the Power Supply PC Board must be re-set to the correct frequency as

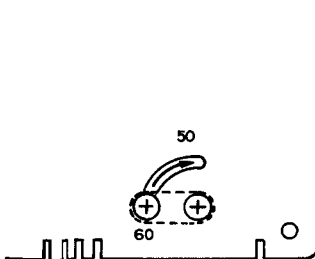

Fig. 10-4 Power Supply PC BD.

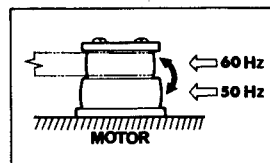

Fig. 10-5 Motor Pulley

indicated in the illustration.

8. Replace the Bottom Cover.

b. VOLTAGE SELECTOR SETTING PROCEDURE (FOR GENERAL EXPORT MODELS)

1. Remove the AC Power Cord from the deck.
2. Take off the 2 screws holding the protective Guard over the Voltage Selector Plug, and remove the Guard.
3. Pull out the Plug and re-insert it so the desired voltage appears in the cut-out window.
4. Re-install the protective Guard.

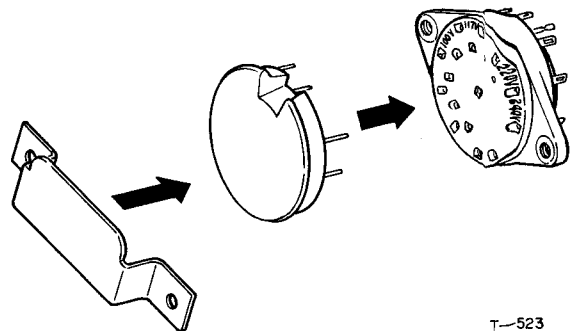

Fig. 10-6 Voltage Conversion

T-523

A-450

Stereo Cassette Deck with Dolby System

TEAC

TEAC CORPORATION

3-7-3 NAKA-CHO MUSASHINO TOKYO PHONE (0422) 53-1111

TEAC CORPORATION OF AMERICA

7733 TELEGRAPH ROAD MONTEBELLO CALIFORNIA 90640 PHONE (213) 726-3303

TEAC AUSTRALIA PTY., LTD.

165-167 GLADSTONE STREET SOUTH MELBOURNE VICTORIA 3205 PHONE 689-6000

PRINTED IN JAPAN 0481 SYU 0.12 D-2396C

TEAC®

A-450

Stereo Cassette Deck with Dolby System

PARTS LIST

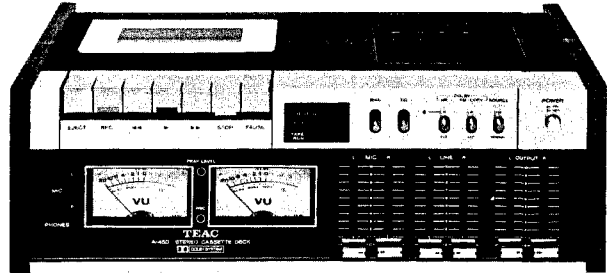

CONTENTS

EXPLODED VIEWS AND PARTS LIST SECTION 2-9

PC BOARD SECTION (Diagram)

1. RECORD/PLAYBACK AMPLIFIER 10
– U.S.A. (later models) –
2. RECORD/PLAYBACK AMPLIFIER 11
– All except U.S.A. (later models) –
3. POWER SUPPLY 12
– U.S.A. (later models) –
4. POWER SUPPLY 12
– All except U.S.A. (later models) –
5. DOLBY B TYPE PROCESSOR 13
6. TRIMMER RESISTORS 14
– U.S.A. (later models) –
7. TRIMMER RESISTORS 14
– All except U.S.A. (later models) –

PC BOARD SECTION (Parts List)

1. RECORD/PLAYBACK AMPLIFIER 14
2. POWER SUPPLY 17
3. TRIMMER RESISTORS 18
– U.S.A. (later models) –
4. TRIMMER RESISTORS 18
– All except U.S.A. (later models) –
5. DOLBY B TYPE PROCESSOR 19

INCLUDED ACCESSORIES 3
ASSEMBLING HARDWARE CODING LIST 20

PARTS ORDERING INFORMATION

Spare parts are available through your nearest TEAC Authorized Service Center or directly from the TEAC office, the address of which is written on the back cover. When ordering parts, always include the following information:

1. MODEL
2. REF. NO.
3. PARTS NO.
4. DESCRIPTION
5. UNIT SERIAL NO.
6. MANUAL CODE NO.

NOTICE REGARDING PARTS ORDERS

1. Do not order by only REF. NO.
2. In some instances, individual minor parts are not available. In such a case, the entire assembly including the part requested will be sent to you.

PARTS IDENTIFICATION CODING

Parts are identical between the different models with the exceptions as coded by the designations explained below.

- | | |
|--------|---|
| JAPAN | Domestic (Japan) market decks only. |
| U.S.A. | TEAC Corporation of America, U.S.A. version only. |
| CANADA | Canada version only. |
| EUROPE | European market decks (except United Kingdom). |
| EXPORT | All decks not specified above (incl. U.K.) |

Parts marked with *require longer delivery time than regular parts.

U.S.A. (later models) as noted in REMARKS column refers to units with BIAS/EQ switch position inscribed 1, 2, 3. Earlier U.S.A. models have BIAS/EQ switch position inscribed CrO₂, HIGH, NORMAL. This note applies to CANADA models also.

EXPLODED VIEWS AND PARTS LIST SECTION

EXPLODED VIEWS - 1 -

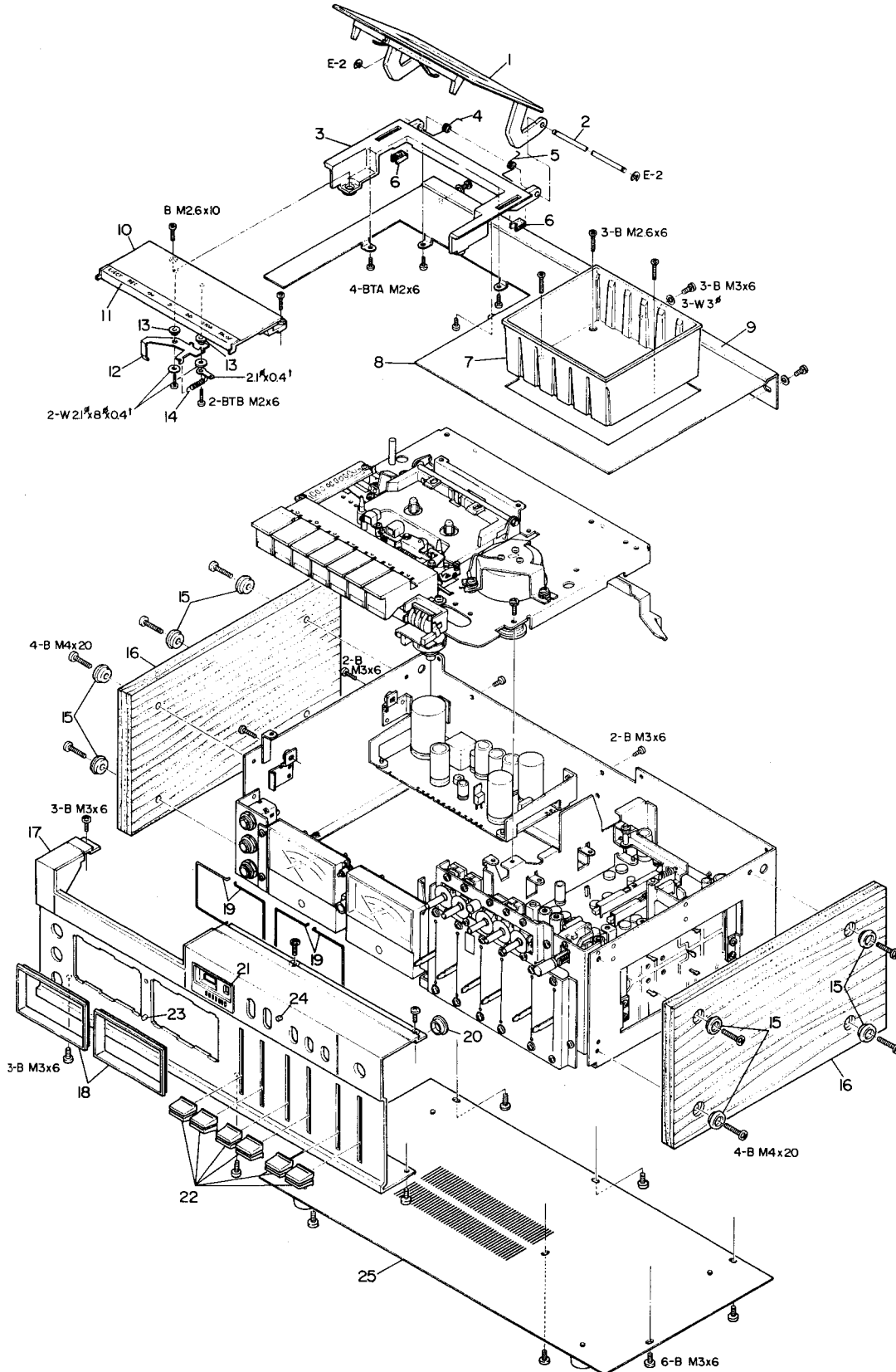

F-001-2

PARTS LIST - 1 -

REF. NO.	PARTS NO.	DESCRIPTION	REMARKS	
1 - 1	55020240	Lid Assy, Cassette	U.S.A. JAPAN, EXPORT, EUROPE	
	55000402	Lid Assy, Cassette		
1 - 2	* 55000520	Shaft, Cassette Lid		
1 - 3	* 55300422	Sideboard, Compartment		
1 - 4	55200322	Spring, Cassette Lid; Left		
1 - 5	55200331	Spring, Cassette Lid; Right		
1 - 6	* 55500990	Cushion, Cassette Lid		
1 - 7	* 55300461	Tray, Cassette Storage		
1 - 8	* 55500951	Cover, Trim Case		
1 - 9	* 55500961	Sash, Trim		
1 - 10	55300413	Cover, Head		
1 - 11	55500842	Panel, Control		
1 - 12	* 55500850	Lever, Hook		
1 - 13	* 55400511	Washer, Shoulder; Hook Lever		
1 - 14	* 55200310	Spring, Hook Lever		
1 - 15	50276931	Washer, Trim		
1 - 16	55400530	Sideboard (or 55430010)		U.S.A. (later models) All except U.S.A. (later models)
1 - 17	* 55520620	Panel, Front		
	* 55500861	Panel, Front		
1 - 18	* 55300380	Escutcheon, VU Meter		
1 - 19	* 55200300	Clamp, Meter Escutcheon		
1 - 20	* 50928730	Guide, Power Switch		
1 - 21	* 55000370	Cover Assy, Counter		
1 - 22	55300441	Knob, Linear Pot.		
1 - 23	* 57243190	Light Cover, REC (Red)		
1 - 24	* 50937960	Light Cover, DOLBY NR (Orange)		
1 - 25	* 55000411	Cover Assy, Bottom		

INCLUDED ACCESSORIES

REF. NO.	PARTS NO.	DESCRIPTION	REMARKS
	51280010	Cords, Input-output Connection, 2 used	U.S.A. EXPORT-100V/117V area EXPORT-220V/240V area U.S.A. (later models) U.S.A. (later models) U.S.A. (earlier models) JAPAN EXPORT EUROPE
	57100300	Cleaning Stick (TZ-275)	
	* 50291350	Silicone Cloth	
	50411440	Fuse, 250V 2A	
	50411140	Fuse, 2A	
	50411010	Fuse, 1A	
	* 51013450	Cassette Supplement	
	* 51013670	A-450 Owner's Manual	
	* 51013250	A-450 Owner's Manual	
	51011630	A-450 Owner's Manual	
	51011640	A-450 Owner's Manual	
	51012680	A-450 Owner's Manual	

EXPLODED VIEWS -2-

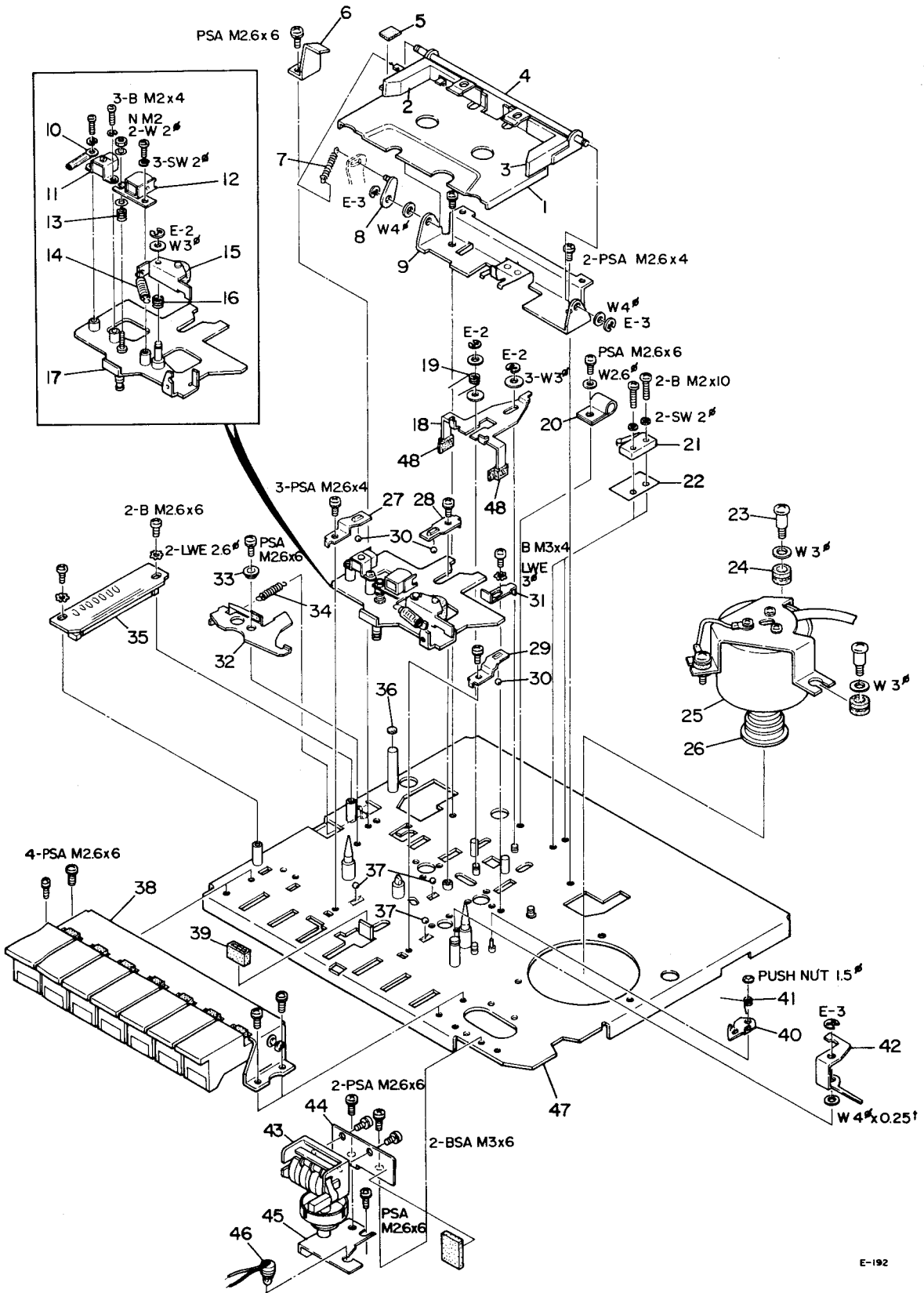

E-192

PARTS LIST -2-

REF. NO.	PARTS NO.	DESCRIPTION	REMARKS
2- 1	* 55500491	Cassette Holder	
2- 2	55300331	Cassette Guide, Left	
2- 3	55341710	Cassette Guide, Right	
2- 4	* 55400471	Shaft, Cassette Holder	
2- 5	* 55500520	Cushion, Cassette Holder Up	
2- 6	* 55500540	Bracket, Stopper; Cassette Up	
2- 7	* 55200240	Spring, Rocker Arm	
2- 8	* 55000280	Arm Assy, Rocker; Cassette Up	
2- 9	* 55042590	Holder Assy, Cassette Holder; A	
2-10	* 50831921	Retainer, Head leads	
2-11	50663070	Head, Erase	
2-12	50660190	Head, Record/Playback	
2-13	55200021	Spring, Head Adjusting	
2-14	55200031	Spring, Pinch Roller	
2-15	55000032	Pinch Roller Assy	
2-16	55200010	Spring, Guide	
2-17	55000022	Plate Assy, Head Base	
2-18	* 55500236	Bracket, Brake	
2-19	* 55200142	Spring, Brake Bracket	
2-20	* 50276290	Clamp, Wire; B	
2-21	50446540	Switch, Micro	
2-22	* 55500251	Spacer, Insul. Paper	
2-23	* 50210100	Screw, Motor Mounting	
2-24	* 50274650	Cushion, Rubber	
2-25	71015013	Motor Assy	
2-26	55400413	Pulley, Motor	
2-27	* 55500040	Plate Spring, Left	
2-28	* 55500060	Plate Spring, Center	
2-29	* 55500050	Plate Spring, Right	
2-30	55400550	Steel Ball, 2 ϕ	
2-31	* 55500550	Bracket, Stopper; Head Base Plate	
2-32	* 55500070	Lever Assy, Muting Switch	
2-33	* 55001151	Washer, Shoulder; Hook Lever Arm	
2-34	* 55200950	Spring, Muting Switch Lever	
2-35	* 51680061	PC Board Assy, Muting Switch	
	50444630	Switch, Slide	
2-36	* 55500580	Cushion, Panel	
2-37	55400560	Steel Ball, 3 ϕ	
2-38	55000266	Pushbutton Assy	
2-39	* 55300350	Cushion, Head Base Plate	
2-40	* 55500270	Plate, Pause Lock	
2-41	* 55200161	Spring, Pause Lock Plate	
2-42	* 55500260	Lever, Pause; B	
2-43	55000250	Counter Assy, Index	
2-44	* 55500340	Plate, Counter; A	
2-45	* 55500351	Plate, Counter; B	
2-46	50414660	Lamp, TAPE RUN Indicator	
2-47	* 55000016	Chassis Assy, Tape Transport	All except EUROPE
	* 55001261	Chassis Assy, Tape Transport	EUROPE
2-48	55300112	Brake Shoe	

EXPLODED VIEWS - 3 -

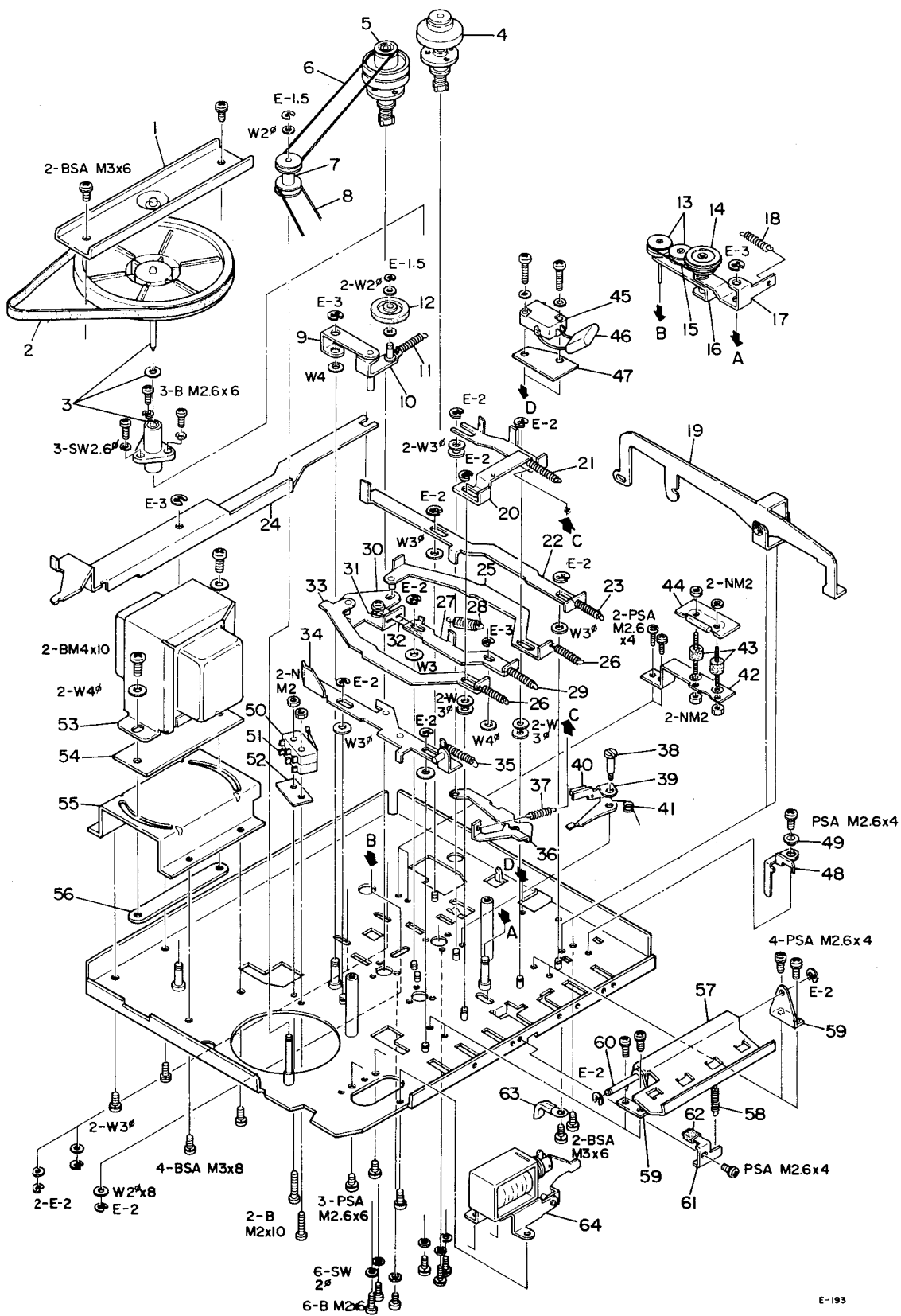

PARTS LIST -3-

REF. NO.	PARTS NO.	DESCRIPTION	REMARKS
3- 1	* 55000200	Plate Assy, Flywheel Bearing	
3- 2	55300150	Belt, Drive	
3- 3	55000482	Capstan Drive Assy	
3- 4	55000243	Reel Table Assy, Left	
3- 5	55000212	Reel Table Assy, Right	
3- 6	55300291	Belt, Counter; Small	
3- 7	55300270	Pulley, Twin Idler	
3- 8	55300281	Belt, Counter; Large	
3- 9	* 55000080	Lever Assy, Idler; A	
3-10	* 55000090	Lever Assy, Idler; B	
3-11	* 55000101	Spring, Idler Lever B	
3-12	55001040	Idler Assy, Play	
3-13	55000120	Roller Assy, Fast Wind; C	
3-14	55000101	Roller Assy, Fast Wind	
3-15	55300100	Belt, Fast Wind	
3-16	* 55000071	Lever Assy, Fast Wind; B	
3-17	* 55000060	Lever Assy, Fast Wind; A	
3-18	* 55200080	Spring, Fast Wind Lever; A	
3-19	* 55000272	Lever Assy, Cassette Up Rocker	
3-20	* 55500111	Lever, F.F.	
3-21	* 55200061	Spring, F.F. Lever	
3-22	* 55500152	Lever, Record	
3-23	* 55200100	Spring, Record Lever	
3-24	* 55500162	Arm, Record/Playback Selector	
3-25	* 55000051	Lever Assy, Fast; Left	
3-26	* 55200071	Spring, Fast Lever	
3-27	* 55500080	Lever, Play	
3-28	* 55200041	Spring, Play	
3-29	* 55200050	Spring, Play Lever	
3-30	* 55500141	Plate, Pressure; Fast Winding	
3-31	* 55400290	Washer, Shoulder; Pressure Plate	
3-32	* 55200090	Spring, Pressure Plate	
3-33	* 55000041	Lever Assy, Fast; Right	
3-34	* 55000152	Lever Assy, Pause; A	
3-35	* 55200151	Spring, Pause Lever A	
3-36	* 55501031	Lever, Play Mode Lock Out	
3-37	* 55200271	Spring, Lever	
3-38	* 55400491	Screw-Shaft, Back Tension	
3-39	* 55500590	Bracket, Back Tension	
3-40	* 55500600	Felt, Back Tension	
3-41	* 55200282	Spring, Back Tension	
3-42	* 55500220	Plate, Reed Switch	
3-43	* 71111900	Cushion, Rubber	
3-44	* 50490441	PC Board Assy, Reed Switch	
	50447350	Switch, Reed	
3-45	50446290	Switch, Micro	All except U.S.A. (later models)
3-46	50529050	Spark Killer 0.1 mfd + 120 ohm 400VAC	All except U.S.A. (later models)
3-47	* 55502482	Insulator Plate	All except U.S.A. (later models)
3-48	* 55500571	Arm, Hook Lever	
3-49	* 55400480	Washer, Shoulder; Hook Lever Arm	
3-50	50446540	Switch, Micro	
3-51	50446540	Switch, Micro	All except U.S.A. (later models)
3-52	* 55500251	Spacer, Insul. Paper	◆ U.S.A.
3-53	51520100	Transformer, Power	CANADA
	50562580	Transformer, Power	JAPAN
	51520082	Transformer, Power	EXPORT
	50562590	Transformer, Power	EUROPE
	50520170	Transformer, Power	U.S.A., JAPAN, EUROPE
3-54	* 55502620	Plate, Power Transformer; C	U.S.A., JAPAN, EUROPE
3-55	* 55502600	Plate, Power Transformer; A	U.S.A., JAPAN, EUROPE
3-56	* 55502610	Plate, Power Transformer; B	U.S.A., JAPAN, EUROPE
3-57	* 55500431	Plate, Pushbutton Holding	
3-58	* 55200230	Spring, Holding Plate	
3-59	* 55500440	Bracket, Holding Plate	
3-60	* 55400430	Shaft, Holding Plate	
3-61	* 55500452	Bracket, Holding Plate Limit	
3-62	* 55300320	Cushion, Holding Plate	
3-63	* 50279870	Retainer, Leads; D	
3-64	55000130	Solenoid Assy, Auto-Stop	

EXPLODED VIEWS -4-

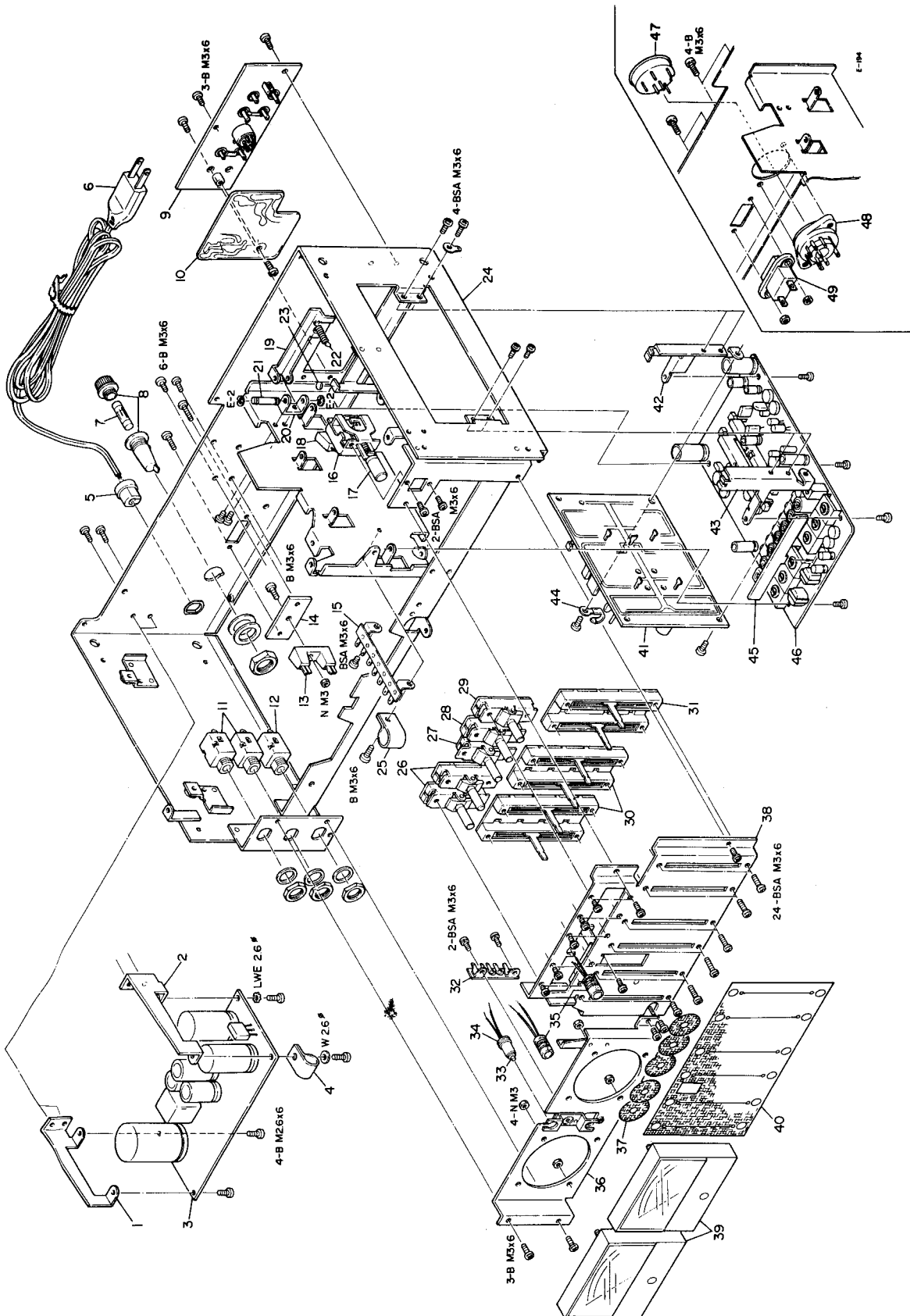

PARTS LIST -4-

REF. NO.	PARTS NO.	DESCRIPTION	REMARKS
4- 1	* 55501020	Angle, PC Board; Left	
4- 2	* 55500940	Angle, PC Board; Right	
4- 3	50491228	PC Board Assy, Power Supply	
4- 4	* 50276290	Clamp, Wire; B	
4- 5	55300470	Strain Relief, AC Power Coard	
4- 6	50471661	Cord, AC Power	U.S.A.
		Cord, AC Power	JAPAN, EXPORT
		Cord, AC Power	EUROPE
4- 7	50411440	Fuse, 2A; UL	U.S.A.
	50411140	Fuse, 2A	JAPAN, EXPORT-100V/117V area
	50411010	Fuse, 1A	EXPORT-220V/240V area
4- 8	* 50412880	Holder, Fuse	U.S.A.
	* 50924500	Holder, Fuse	JAPAN, EXPORT
4- 9	* 50260180	Terminal Assy	
4-10	* 51682290	PC Board Assy, Trimmer Resistors	U.S.A. (later models)
	* 50491211	PC Board Assy, Trimmer Resistors	All except U.S.A. (later models)
4-11	50432970	Jack, Phone; Single	
4-12	50432980	Jack, Phone; 3 cond.	
4-13	* 50438350	Terminal Strip, 2P	
4-14	* 55540850	Mask, Outlet	
4-15	* 51260051	Terminal Strip, 2L-5P	
4-16	50444500	Switch, Push; Power	U.S.A.
	50443870	Switch, Push; Power	JAPAN, EXPORT
	50444710	Switch, Push; Power	EUROPE
4-17	55400540	Pushbutton, Power Switch	All except EUROPE
	55440430	Pushbutton, Power Switch	EUROPE
4-18	50529060	Spark Killer, 0.033 mfd + 120 ohm	U.S.A. (later models)
	50529060	Spark Killer, 0.1 mfd + 120 ohm	U.S.A. (earlier models)
	50529050	Spark Killer, 0.1 mfd + 120 ohm	JAPAN, EXPORT
	50529080	Spark Killer, 4700 pfd + 120 ohm	EUROPE
4-19	* 55500740	Arm, Mode Select Switch	
4-20	* 55500730	Bracket, Mode Select Switch Arm	
4-21	* 55400500	Shaft, Mode Select Switch Arm	
4-22	* 55200291	Spring, Mode Select Switch Arm	
4-23	* 55500580	Cushion, Panel	
4-24	* 55000314	Chassis Assy, Ampl.	U.S.A., JAPAN
	* 55000324	Chassis Assy, Ampl.	EXPORT
	* 55001281	Chassis Assy, Ampl.	EUROPE
4-25	* 50276280	Clamp, Wire; A	
4-26	50447310	Switch, Lever; F	
4-27	50447231	Switch, Lever; C	
4-28	50447340	Switch, Lever; I	
4-29	50447330	Switch, Lever; H	U.S.A.
	50447320	Switch, Lever; G	JAPAN, EXPORT, EUROPE
4-30	51500510	Linear Pot., 50k ohm A x 2	
4-31	51500520	Linear Pot., 20k ohm A x 2	
4-32	* 50452531	Terminal Strip, 2L-3P	
4-33	50422890	Diode, Light Emitting	
4-34	* 55300360	Cushion, LED	
4-35	50414650	Lamp	
4-36	* 55000340	Plate Assy, VU Meter	
4-37	55500790	Boot, Control Switch	
4-38	* 55500770	Plate, Linear Pot.	
4-39	50581421	VU Meter	
4-40	* 55500780	Mask, Linear Pot.	
4-41	50491201	PC Board Assy, Dolby B-Type Processer	
4-42	* 55500750	Bracket, Dolby PC Board; Left	
4-43	* 55500760	Bracket, Dolby PC Board; Right	
4-44	* 50279870	Clamp, Wire; D	
4-45	* 51672440	PC Board, Shield	
4-46	51682713	PC Board Assy, Record/Playback Ampl.	U.S.A., CANADA
	-50491234	PC Board Assy, Record/Playback Ampl.	JAPAN, EXPORT, EUROPE
4-47	50434711	Plug, Voltage Selector	EXPORT
4-48	* 50435020	Socket, Voltage Selector	EXPORT
4-49	* 50431170	Outlet, AC	JAPAN, EXPORT

PC BOARD SECTION (Diagram)

1. RECORD/PLAYBACK AMPLIFIER

- U.S.A. (later models) -

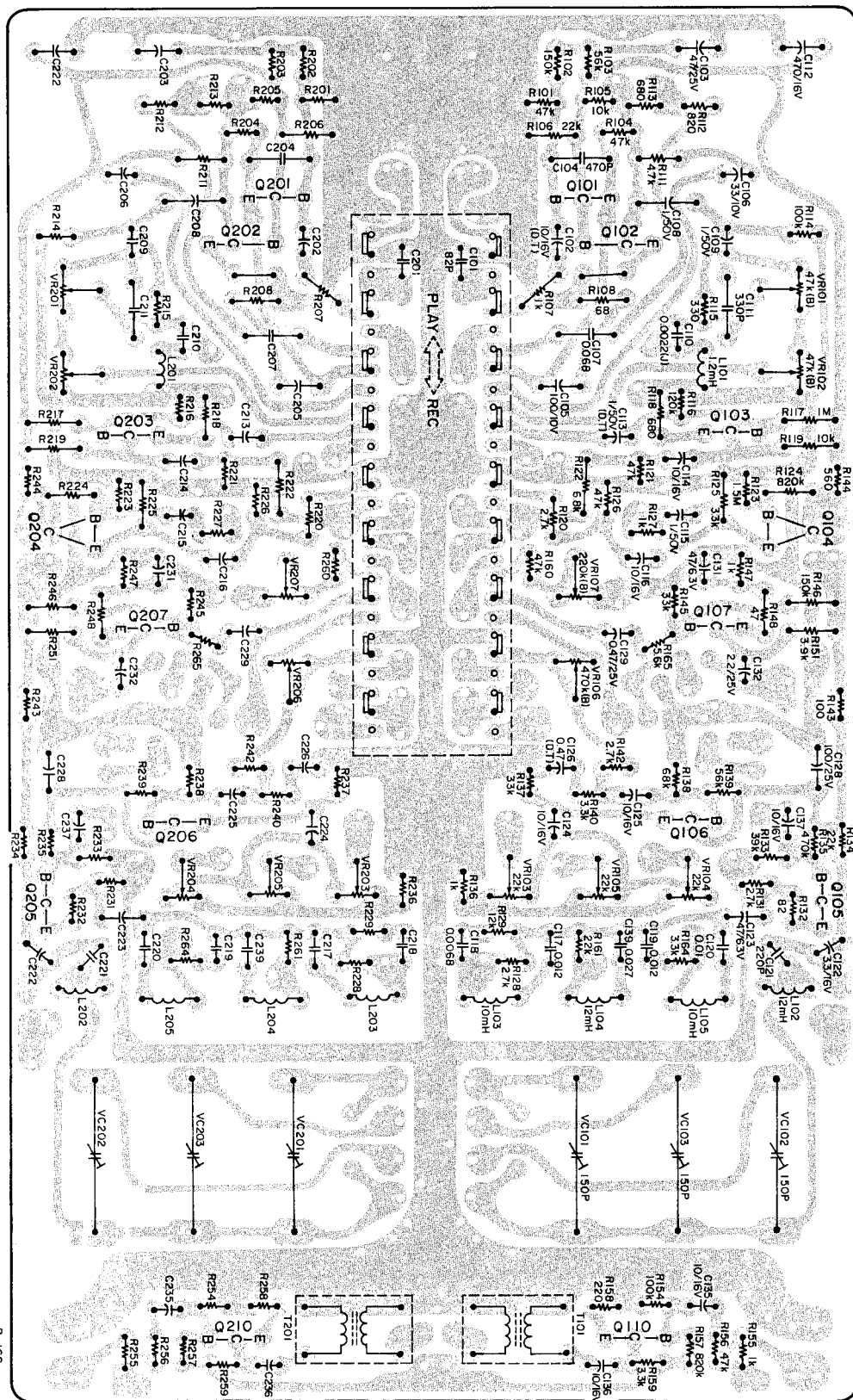

2. RECORD/PLAYBACK AMPLIFIER

-All except U.S.A. (later models) -

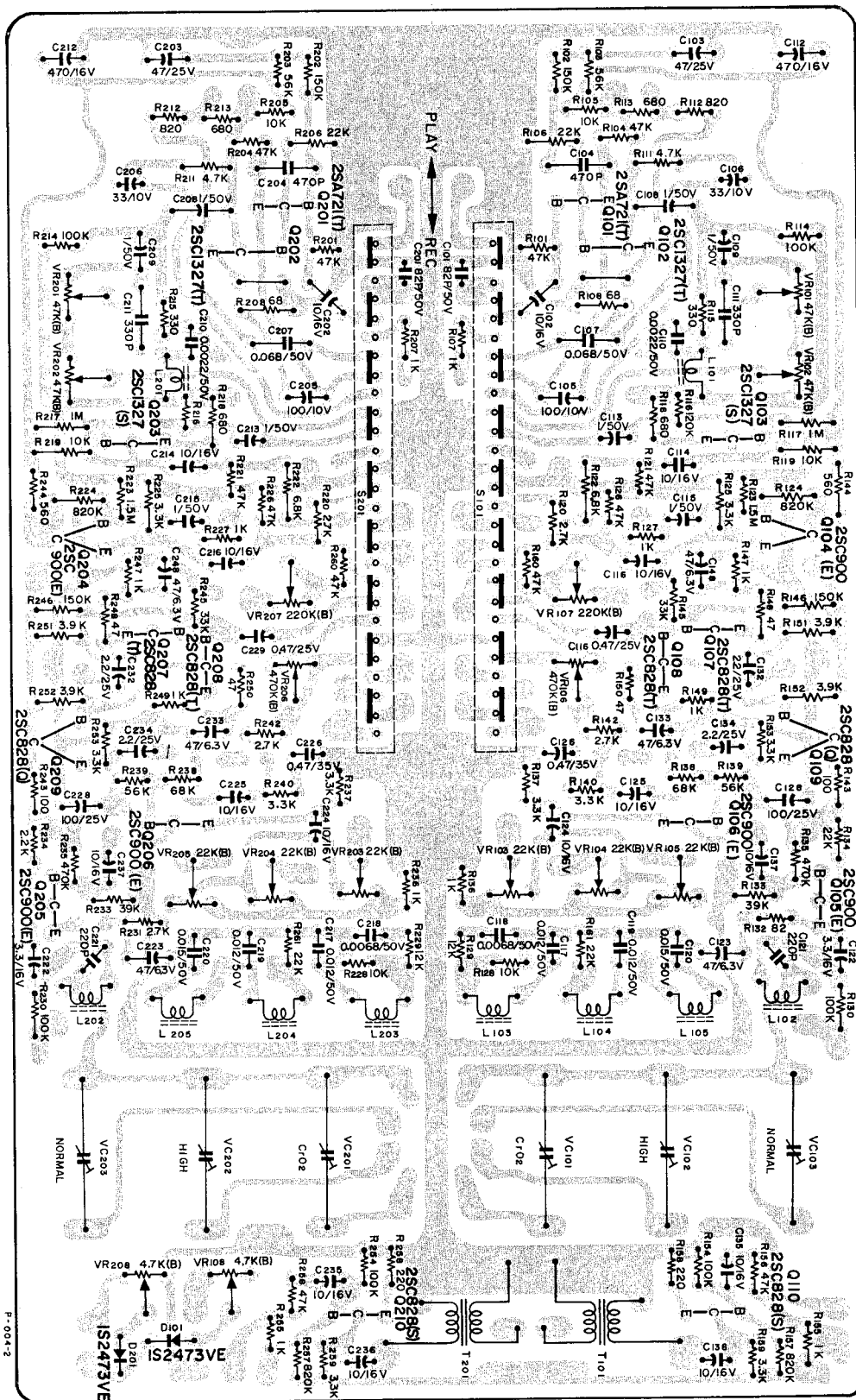

F-004-2

3. POWER SUPPLY -U.S.A. (later models) -

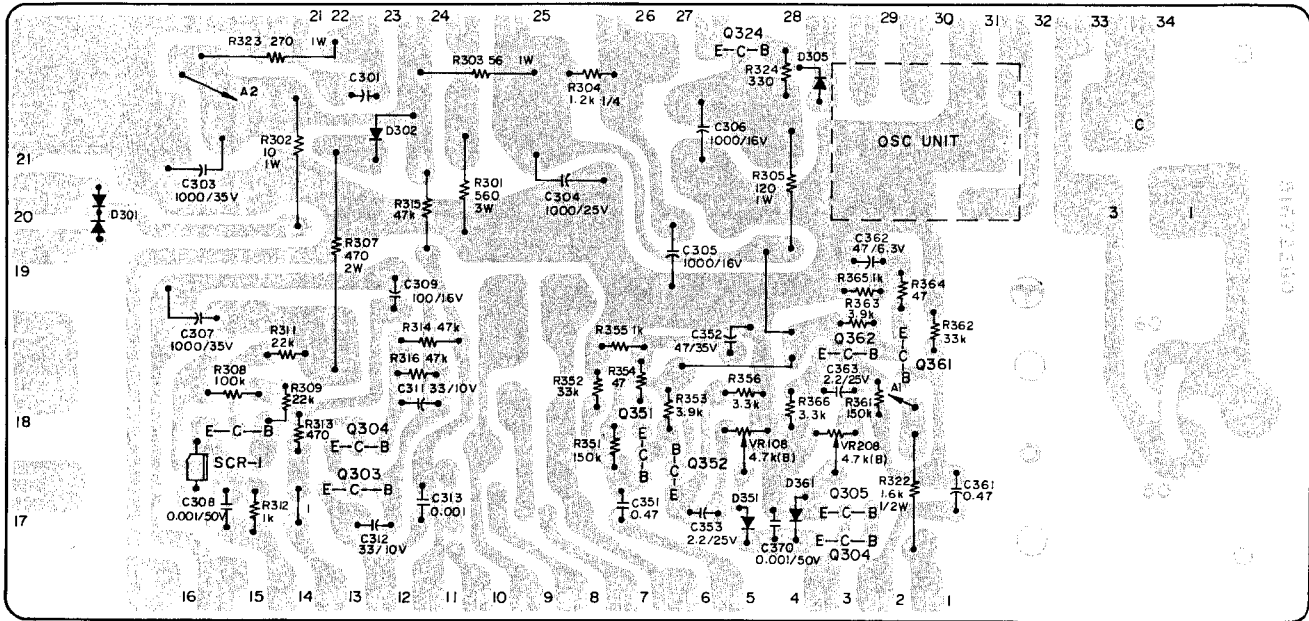

P-175

4. POWER SUPPLY -All except U.S.A. (later models) -

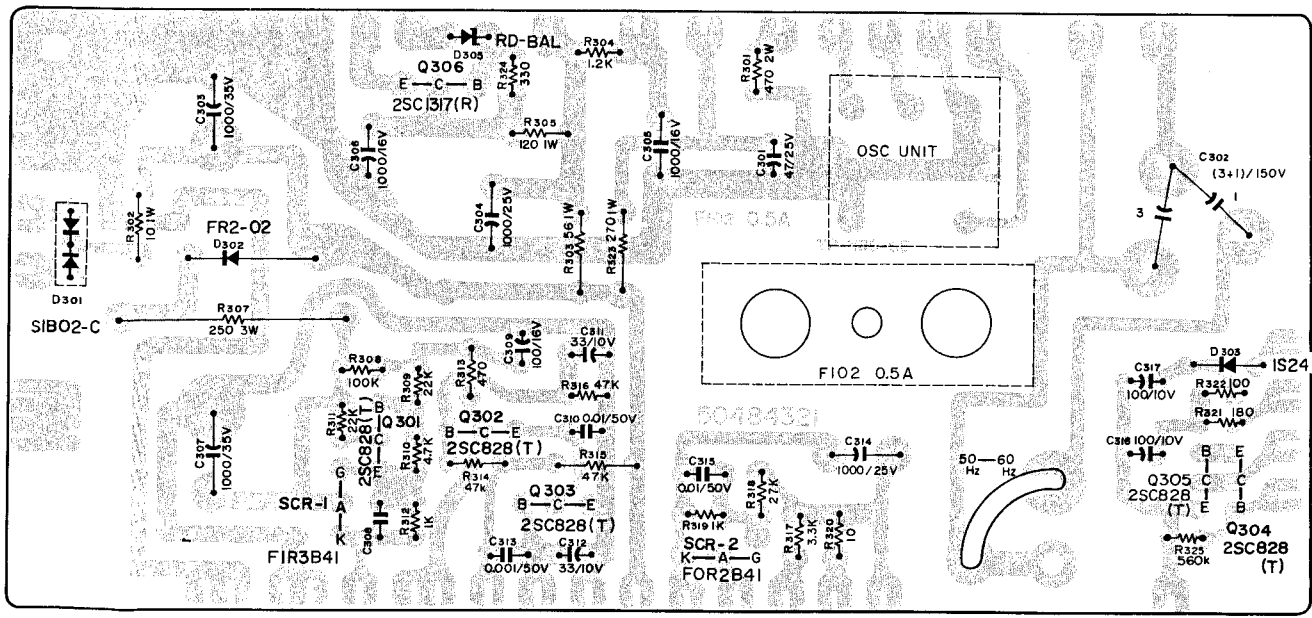

P-003-1

5. DOLBY B TYPE PROCESSOR

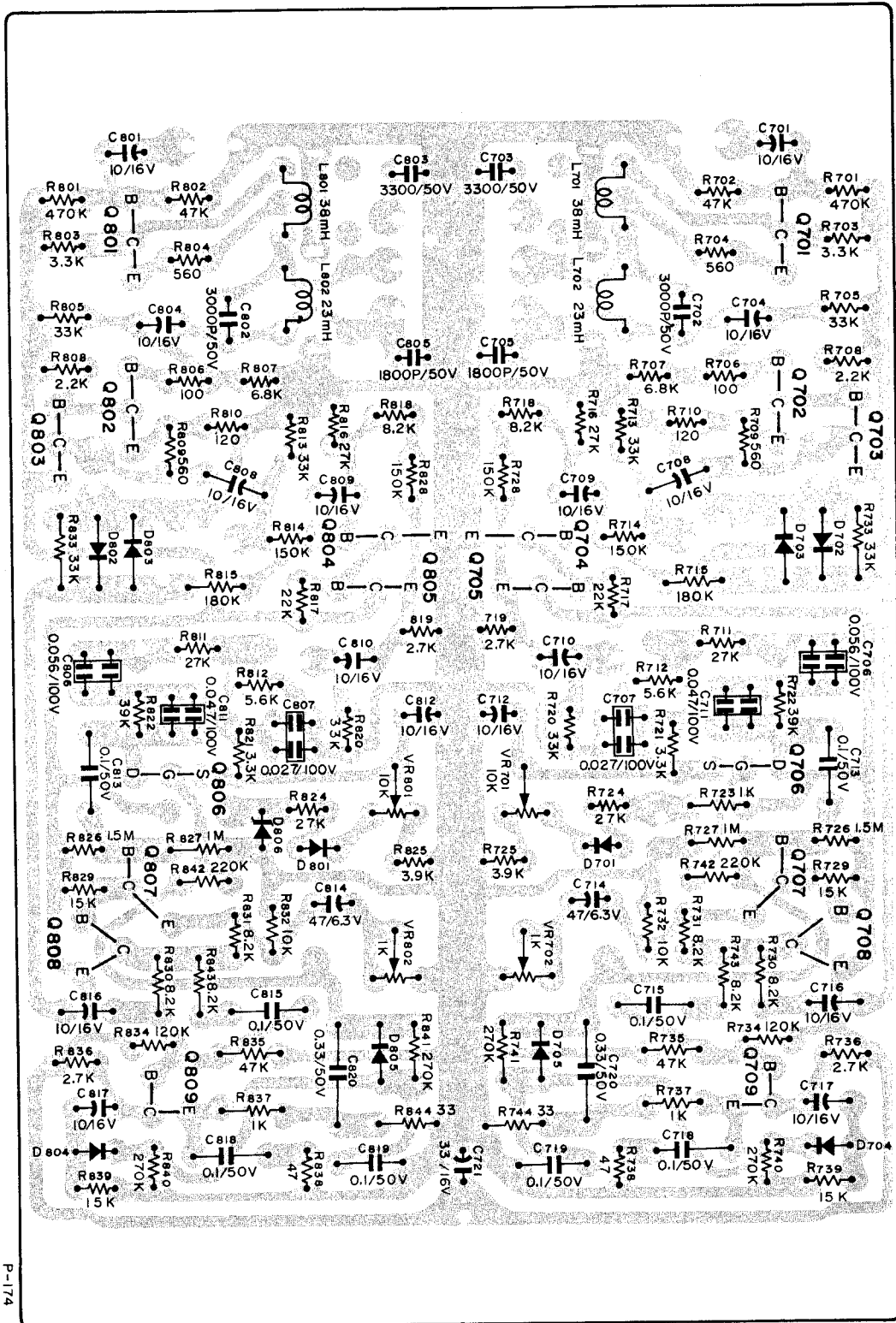

P-174

6. TRIMMER RESISTORS

—U.S.A. (later models) —

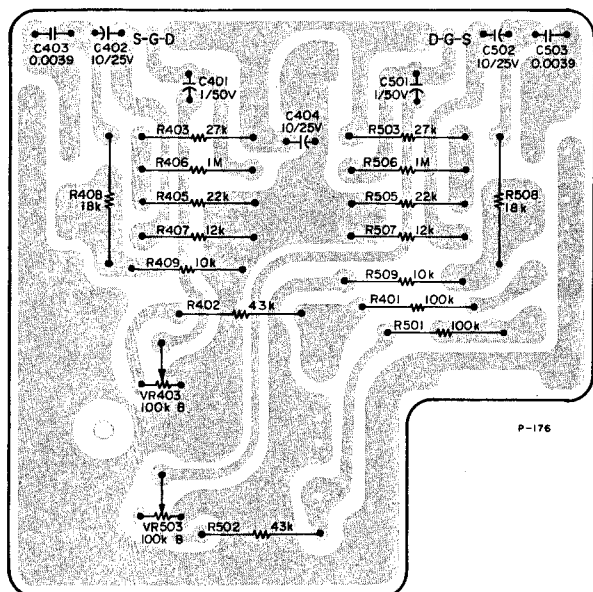

7. TRIMMER RESISTORS

—All except U.S.A. (later models) —

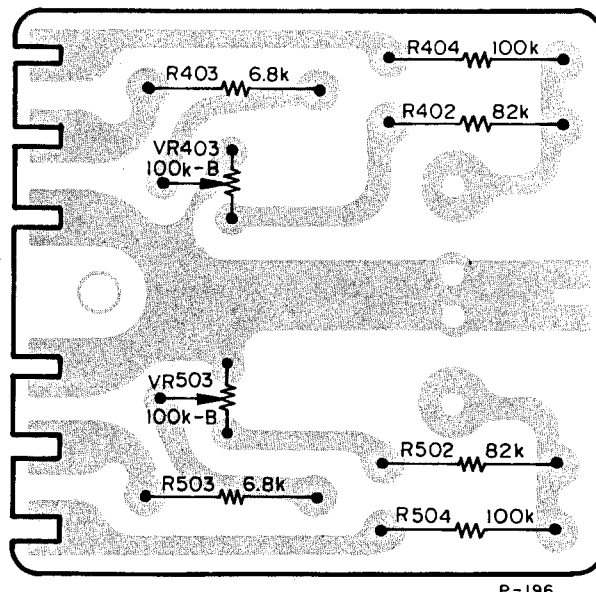

PC BOARD SECTION (Parts List)

1. RECORD/PLAYBACK AMPLIFIER

REF. NO.	PARTS NO.	DESCRIPTION	REMARKS
	51682711	PC Bd. Assy	U.S.A. (later models)
	50491235	PC Bd. Assy	All except U.S.A. (later models)
	51672300	PC Board	U.S.A. (later models)
	50484331	PC Board	All except U.S.A. (later models)
TRANSISTORS			
Q101/Q201	50424650	2SA721 (T)	
Q102/Q202	50424610	2SC1327 (T)	
Q103/Q203	50424610	2SC1327 (T) or (S)	
Q104/Q204	50424940	2SC900 (E)	
Q105/Q205	50424940	2SC900 (E)	
Q106/Q206	50424940	2SC900 (E)	
Q107/Q207	50424230	2SC828 (T)	
Q108/Q208	50424230	2SC828 (T)	
Q109/Q209	50423600	2SC828 (Q)	All except U.S.A. (later models)
Q110/Q210	50424600	2SC828 (S)	All except (later models)
DIODES			
D101/D201	50425170	1S2473VE	All except (later models)

REF. NO.	PARTS NO.	DESCRIPTION	REMARKS
CARBON RESISTORS			
All resistors are rated $\pm 5\%$ tolerance and 1/4 watt.			
R101/R201	50571221	47k ohm (SG)	
R102/R202	50571341	150k ohm (SG)	
R103/R203	50571240	56k ohm	
R104/R204	50571221	47k ohm (SG)	
R105/R205	50571060	10k ohm	
R106/R206	50571141	22k ohm (SG)	
R107/R207	50570820	1k ohm	
R108/R208	50570540	68 ohm	
R111/R211	50570980	4.7k ohm	
R112/R212	50570800	820 ohm	
R113/R213	50570780	680 ohm	
R114/R214	50571300	100k ohm	
R115/R215	50570700	330 ohm	
R116/R216	50571320	120k ohm	
R117/R217	50571540	1M ohm	
R118/R218	50570780	680 ohm	
R119/R219	50571060	10k ohm	
R120/R220	50570920	2.7k ohm	
R121/R221	50571220	47k ohm	
R122/R222	50571020	6.8k ohm	
R123/R223	50571580	1.5M ohm	
R124/R224	50571520	820k ohm	
R125/R225	50570940	3.3k ohm	
R126/R226	50571220	47k ohm	
R127/R227	50570820	1k ohm	
R128/R228	50571060	10k ohm	
R129/R229	50571080	12k ohm	
R130/R230	50571300	100k ohm	
R131/R231	50570920	2.7k ohm	
R132/R232	50570560	82 ohm	
R133/R233	50571200	39k ohm	
R134/R234	50571140	22k ohm	
R135/R235	50571460	470k ohm	
R136/R236	50570820	1k ohm	
R137/R237	50570940	3.3k ohm	
R138/R238	50571260	68k ohm	
R139/R239	50571240	56k ohm	
R140/R240	50570940	3.3k ohm	
R142/R242	50570920	2.7k ohm	
R143/R243	50570580	100 ohm	
R144/R244	50570760	560 ohm	
R145/R245	50570940	33k ohm	
R146/R246	50571340	150k ohm	
R147/R247	50570820	1k ohm	
R148/R248	50570500	47 ohm	
R149/R249	50570820	1k ohm	All except U.S.A. (later models)
R150/R250	50570500	47 ohm	All except U.S.A. (later models)
R151/R251	50570960	3.9k ohm	
R152/R252	50570960	3.9k ohm	All except U.S.A. (later models)
R153/R253	50570940	3.3k ohm	All except U.S.A. (later models)
R154/R254	50571300	100k ohm	
R155/R255	50570820	1k ohm	
R156/R256	50571220	47k ohm	
R157/R257	50571520	820k ohm	
R158/R258	50570660	220 ohm	
R159/R259	50570940	3.3k ohm	
R160/R260	50571220	47k ohm	
R161/R261	50571140	22k ohm	
R164/R264	50570940	3.3k ohm	U.S.A. (later models)
R165/R265	50571000	5.6k ohm	U.S.A. (later models)
CAPACITORS			
C101/C201	50547580	Dip. Mica	82 pfd 50V
C102/C202	50546561	Dip. Tant.	10 mfd 16V
C103/C203	50554490	Elec.	47 mfd 25V

REF. NO.	PARTS NO.	DESCRIPTION	REMARKS
C104/C204	50547560	Dip. Mica 470 pfd	50V
C105/C205	50554570	Elec. 100 mfd	10V
C106/C206	50554240	Elec. 33 mfd	10V
C107/C207	50549260	Mylar 0.068 mfd	50V 5%
C108/C208	51700860	Elec. 1 mfd	50V (LR)
C109/C209	51700860	Elec. 1 mfd	50V (LR)
C110/C210	50548760	Mylar	
C111/C211	50547460	Dip. Mica 330 pfd	50V
C112/C212	50554400	Elec. 470 mfd	16V
C113/C213	51700860	Elec. 1 mfd	50V (LR)
C114/C214	51700770	Elec. 10 mfd	16V (LR)
C115/C215	51700860	Elec. 1 mfd	50V (LR)
C116/C216	51700770	Elec. 10 mfd	16V (LR)
C117/C217	50548950	Mylar 0.012 mfd	50V 5%
C118/C218	50548930	Mylar 0.0068 mfd	50V 5%
C119/C219	50548950	Mylar 0.012 mfd	50V 5%
C120/C220	50548770	Mylar 0.01 mfd	50V 5%
	50548960	Mylar 0.015 mfd	50V 5%
C121/C221	50543420	Polyst. 220 pfd	50V
C122/C222	50546531	Dip. Tant. 3.3 mfd	16V
C123/C223	50554030	Elec. 47 mfd	6.3V
C124/C224	50554050	Elec. 10 mfd	16V
C125/C225	51700700	Elec. 10 mfd	16V (LR)
C126/C226	50549650	Elec. 0.47 mfd	25V (KU)
C128/C228	50554170	Elec. 100 mfd	25V
C129/C229	50549650	Elec. 0.47 mfd	25V (KU)
C130/C230	50548320	Mylar 0.001 mfd	50V
C131/C231	50554030	Elec. 47 mfd	6.3V
C132/C232	50554930	Elec. 2.2 mfd	25V
C133/C233	50554030	Elec. 47 mfd	6.3V
C134/C234	50554930	Elec. 2.2 mfd	25V
C135/C235	50554050	Elec. 10 mfd	16V
C136/C236	50554050	Elec. 10 mfd	16V
C137/C237	50554050	Elec. 10 mfd	16V
C139/C239	50548990	Mylar 0.027 mfd	50V 5%
			U.S.A. (later models) All except U.S.A. (later models)
VARIABLE RESISTORS			
VR101/VR201	50533520	Semi-fixed, 47k ohm - B	
VR102/VR202	50533520	Semi-fixed, 47k ohm - B	
VR103/VR203	50533560	Semi-fixed, 22k ohm - B	
VR104/VR204	50533560	Semi-fixed, 22k ohm - B	
VR105/VR205	50533560	Semi-fixed, 22k ohm - B	
VR106/VR206	50534050	Semi-fixed, 470k ohm - B	
VR107/VR207	50533570	Semi-fixed, 220k ohm - B	
VR108/VR208	50533460	Semi-fixed, 4.7k ohm - B	
			All except U.S.A. (later models)
TRIMMER CAPACITORS			
VC101/VC201	51700170	150 pfd Max.	U.S.A. (later models)
	50547020	210 pfd Max.	All except U.S.A. (later models)
VC102/VC202	51700170	150 pfd Max.	U.S.A. (later models)
	50547020	210 pfd Max.	All except U.S.A. (later models)
VC103/VC203	51700170	150 pfd Max.	U.S.A. (later models)
	50547020	210 pfd Max.	All except U.S.A. (later models)
COILS/TRANSFORMERS			
L101/L201	50566611	Coil, Choke; 1.2mH	
L102/L202	50566550	Coil, Trap; 12mH	
L103/L203	50562630	Coil, Record EQ; 10mH	
L104/L204	50562640	Coil, Record EQ; 12mH	
L105/L205	50562630	Coil, Record EQ; 10mH	
	50562650	Coil, Record EQ; 15mH	
T101/T201	50562260	Transformer, Output; 3k ohm:8 ohm or	
	51520740	Transformer, Output; 3k ohm:8 ohm	
			U.S.A. (later models) All except U.S.A. (later models)
MISCELLANEOUS			
S101/S201	50444620	Switch, Slide; 9PDT	

2. POWER SUPPLY

REF. NO.	PARTS NO.	DESCRIPTION	REMARKS
	51682740	PC Bd. Assy	U.S.A. (later models)
	50491228	PC Bd. Assy	All except U.S.A. (later models)
	51672280	PC Board	U.S.A. (later models)
	50484323	PC Board	All except U.S.A. (later models)
TRANSISTORS			
Q301~Q305	50424230	2SC828 (T)	
Q306	50424670	2SC1317 (R)	
Q351, Q352	50423600	2SC828 (Q)	U.S.A. (later models)
Q361, Q362	50423600	2SC828 (Q)	U.S.A. (later models)
SEMICONDUCTORS			
D301	50425250	Silicon Stack	SIB02-C
D302	50422340	Diode, Silicon	FR2-02
D303	50425170	Diode, Silicon	1S2473VE
D305	50425090	Diode, Zener	RD-12EB
D351, D361	50425170	Diode, Silicon	1S2473VE
SCR-1	50428030	Thyristor	FIR3B41
SCR-2	50428040	Thyristor	FOR2B41
RESISTORS			
R301	50527760	Wire Wound	560 ohm 3W
	51807080	Metal Oxide Film	470 ohm 2W
R302	50525460	Metal Oxide Film	10 ohm 1W
R303	50527200	Metal Oxide Film	56 ohm 1W
R304	50570840	Carbon	1.2k ohm 1/4W 5%
R305	50527230	Metal Oxide Film	120 ohm 1W
R307	50527050	Metal Oxide Film	470 ohm 2W
	50527120	Metal Oxide Film	250 ohm 3W
R308	50571300	Carbon	100k ohm 1/4W 5%
R309	50571140	Carbon	22k ohm 1/4W 5%
R310	50570980	Carbon	4.7k ohm 1/4W 5%
R311	50571140	Carbon	22k ohm 1/4W 5%
R312	50570820	Carbon	1k ohm 1/4W 5%
R313	50570740	Carbon	470 ohm 1/4W 5%
R314	50571220	Carbon	47k ohm 1/4W 5%
R315	50571220	Carbon	47k ohm 1/4W 5%
R316	50571220	Carbon	47k ohm 1/4W 5%
R317	50570940	Carbon	3.3k ohm 1/4W 5%
R318	50571160	Carbon	27k ohm 1/4W 5%
R319	50570820	Carbon	1k ohm 1/4W 5%
R320	50570340	Carbon	10 ohm 1/4W 5%
R321	50570640	Carbon	180 ohm 1/4W 5%
R322	50574870	Carbon	1.6k ohm 1/2W
	50570580	Carbon	100 ohm 1/4W 5%
R323	50527330	Metal Oxide Film	270 ohm 1W
R324	50570700	Carbon	330 ohm 1/4W 5%
R325	50571480	Carbon	560k ohm 1/4W 5%
R351, R361	50571341	Carbon	150k ohm 1/4W 5%
R352, R362	50571181	Carbon	33k ohm 1/4W 5%
R353, R363	50570960	Carbon	3.9k ohm 1/4W 5%
R354, R364	50570500	Carbon	47 ohm 1/4W 5%
R355, R365	50570820	Carbon	1k ohm 1/4W 5%
R356, R366	50570940	Carbon	3.3k ohm 1/4W 5%
CAPACITORS			
C301	50554490	Elec.	47 mfd 25V
C302	50545930	MP	(3 + 1) mfd 150 VAC
C303	51700110	Elec.	1000 mfd 35V
	50551380	Elec.	1000 mfd 35V
C304	50555580	Elec.	1000 mfd 25V
C305, C306	50554890	Elec.	1000 mfd 16V
C307	51700110	Elec.	1000 mfd 35V
	50551380	Elec.	1000 mfd 35V

REF. NO.	PARTS NO.	DESCRIPTION	REMARKS
C308	50548020	Mylar 0.01 mfd 50V	
C309	50554200	Elec. 100 mfd 16V	
C310	50548020	Mylar 0.01 mfd 50V	
C311, C312	50554240	Elec. 33 mfd 10V	
C313	50548320	Mylar 0.001 mfd 50V	
C314	50555580	Elec. 1000 mfd 25V	All except U.S.A. (later models)
C315	50548320	Mylar 0.01 mfd 50V	All except U.S.A. (later models)
C316, C317	50554570	Elec. 100 mfd 10V (SL)	All except U.S.A. (later models)
C351, C361	51700850	Elec. 0.47 mfd 50V (LR)	U.S.A. (later models)
C352, C362	50554030	Elec. 47 mfd 6.3V	U.S.A. (later models)
C353, C363	50554940	Elec. 2.2 mfd 25V	U.S.A. (later models)
C370	50548020	Mylar 0.01 mfd 50V	U.S.A. (later models)
VIRIABLE RESISTORS			
VR108, VR208	50533460	Semi-fixed, 4.7k ohm-B	U.S.A. (later models)
MISCELLANEOUS			
S301	50332370	Plate	JAPAN, EXPORT, EUROPE
	50400820	Oscillator Unit, 100k Hz	

3. TRIMMER RESISTORS

—U.S.A. (later models) —

REF. NO.	PARTS NO.	DESCRIPTION	REMARKS
	51682290	PC Bd. Assy	
	51672290	PC Board	
Q401/Q501	50423840	FET 2SK 30A (Y)	
R401/R501	50573300	Resistor, Carbon 100k ohm 1/4W 5%	
R402/R502	50573210	Resistor, Carbon 43k ohm 1/4W 5%	
R403/R503	50573160	Resistor, Carbon 27k ohm 1/4W 5%	
R405/R505	50573140	Resistor, Carbon 22k ohm 1/4W 5%	
R406/R506	50573540	Resistor, Carbon 1M ohm 1/4W 5%	
R407/R507	50573080	Resistor, Carbon 12k ohm 1/4W 5%	
R408/R508	50573120	Resistor, Carbon 18k ohm 1/4W 5%	
R409/R509	50573060	Resistor, Carbon 10k ohm 1/4W 5%	
C401/C501	50554540	Capacitor, Elec. 1 mfd 50V	
C402/C502	50554040	Capacitor, Elec. 10 mfd 25V	
C403/C503	50548900	Capacitor, Mylar 0.0039 mfd 50V 5%	
C404	50554040	Capacitor, Elec. 10 mfd 25V	
VR403/VR503	50534060	Trimmer Resistor 100k ohm - B	

4. TRIMMER RESISTORS

—All except U.S.A. (later models) —

REF. NO.	PARTS NO.	DESCRIPTION	REMARKS
	50491211	PC Bd. Assy	
	50484311	PC Board	
R402/R502	50573280	Resistor, Carbon 82k ohm 1/4W 5%	
R403/R503	50573020	Resistor, Carbon 6.8k ohm 1/4W 5%	
R404/R504	50573300	Resistor, Carbon 100k ohm 1/4W 5%	
VR403/VR503	50534060	Trimmer Resistor 100k ohm - B	

5. DOLBY B TYPE PROCESSOR

REF. NO.	PARTS NO.	DESCRIPTION	REF. NO.	PARTS NO.	DESCRIPTION
	50491201	PC Bd. Assy	R730/R830	50571040	8.2k ohm
	50484301	PC Board	R731/R831	50571040	8.2k ohm
			R732/R832	50571060	10k ohm
			R733/R833	50571180	33k ohm
			R734/R834	50571320	120k ohm
			R735/R835	50571220	47k ohm
			R736/R836	50570920	2.7k ohm
			R737/R837	50570820	1k ohm
			R738/R838	50570500	47k ohm
			R739/R839	50571100	15k ohm
			R740/R840	50571400	270k ohm
			R741/R841	50571400	270k ohm
			R742/R842	50571380	220k ohm
			R743/R843	50571040	8.2k ohm
			R744/R844	50571040	33 ohm
TRANSISTORS					
Q701/Q801	50424610	2SC1327 (T) or			
	50424340	2SC1000 (BL)			
Q702/Q802	50423590	2SC644 (S) or			
	50424100	2SC1000 (GR)			
Q703/Q803	50424210	2SA666 I S or			
	50424321	2SA493 (GR)			
Q704/Q804	50424940	2SC900 E			
Q705/Q805	50423590	2SC644 (S) or			
	50424100	2SC1000 (GR)			
Q706/Q806	57240981	FET 2SK30 (DA) or			
	57240991	FET 2SK30 (DB)			
Q707/Q807	50424610	2SC1327 (T) or			
	50424100	2SC1000 (GR)			
Q708/Q808	50424210	2SA666 I S or			
	50424320	2SA493 (GR)			
Q709/Q809	50424940	2SC900 E			
DIODES					
D701/D801	50422180	Silicon M8513A-R			
D702/D802	50422180	Silicon M8513A-R			
D703/D803	50422180	Silicon M8513A-R			
D704/D804	50422170	Germanium 1N60			
D705/D805	50422180	Silicon M8513A-R			
D806	50425190	Zener WZ075 or			
	50422640	Zener O2Z-7.5A			
CARBON RESISTORS					
All resistors are rated $\pm 5\%$ tolerance and 1/4 watt and of carbon type unless otherwise noted.					
R701/R801	50571460	470k ohm			
R702/R802	50571220	47k ohm			
R703/R803	50570940	3.3k ohm			
R704/R804	50570760	560 ohm			
R705/R805	50571180	33k ohm			
R706/R806	50570580	100 ohm			
R707/R807	50571020	6.8k ohm			
R708/R808	50570900	2.2k ohm			
R709/R809	50570760	560 ohm			
R710/R810	50570600	120 ohm			
R711/R811	51813930	Metal Film 27k ohm	1/2W 1%		
R712/R812	51813920	Metal Film 5.6k ohm	1/2W 1%		
R713/R813	50571180	33k ohm			
R714/R814	51813850	Metal Film 150k ohm	1/4W 2%		
R715/R815	51813860	Metal Film 180k ohm	1/4W 2%		
R716/R816	50571160	27k ohm			
R717/R817	50571140	22k ohm			
R718/R818	50571040	8.2k ohm			
R719/R819	50570920	2.7k ohm			
R720/R820	50571182	33k ohm			
R721/R821	51813910	Metal Film 3.3k ohm	1/2W 1%		
R722/R822	50571200	39k ohm			
R723	50570820	1k ohm			
R724/R824	50571160	27k ohm			
R725/R825	50570960	3.9k ohm			
R726/R826	50571580	1.5k ohm			
R727/R827	50571540	1M ohm			
R728/R828	51813850	Metal Film 150k ohm	1/4W 2%		
R729/R829	50571100	15k ohm			
CAPACITORS					
C701/C801	50554050	Elec.	10 mfd	16V	
C702/C802	50596810	Polyst.	3000 pfd	50V 5%	
C703/C803	50596800	Polyst.	3300 pfd	50V 5%	
C704/C804	50554050	Elec.	10 mfd	16V	
C705/C805	50543990	Polyst.	1800 pfd	50V 5%	
C706/C806	51700130	Mylar	0.0056 mfd	100V 1%	
C707/C807	51700140	Mylar	0.027 mfd	100V 1%	
C708/C808	50554050	Elec.	10 mfd	16V	
C709/C809	50554050	Elec.	10 mfd	16V	
C710/C810	50554050	Elec.	10 mfd.	16V	
C711/C811	51700120	Mylar	0.0047 mfd	100V 1%	
C712/C812	50554050	Elec.	10 mfd	16V	
C713/C813	50548040	Mylar	0.1 mfd	50V 5%	
C714/C814	50554030	Elec.	47 mfd	6.3V	
C715/C815	50548040	Mylar	0.1 mfd	50V	
C716/C816	50554050	Elec.	10 mfd	16V	
C717/C817	50546561	Dip. Tant.	10 mfd	10V 5%	
C718/C818	50548040	Mylar	0.1 mfd	50V 5%	
C719/C819	50548040	Mylar	0.1 mfd	50V 5%	
C720/C820	50548830	Metalized Mylar	0.33 mfd	50V	
C721	50554260	Elec.	33 mfd	16V	
VARIABLE RESISTORS					
VR701/VR801	50533480	10k ohm B			
VR702/VR802	50533500	1k ohm B			
COILS					
L701/L801	50566660	Choke	38mH 5% Fixed		
L702/L802	50566650	Choke	23mH Adjustable		

ASSEMBLING HARDWARE CODING LIST

All screws conform to ISO standards, and have crossrecessed heads, unless otherwise noted. ISO screws have the head inscribed with a point as in the figure to the right.

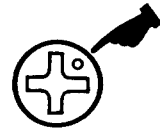

FOR EXAMPLE:

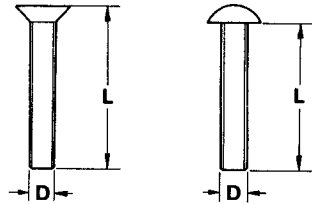
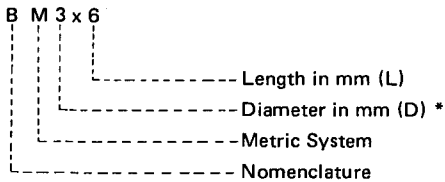

* Inner dia. for washers and nuts

	Code	Name	Type		Code	Name	Type
MACHINE SCREW	R	Round Head Screw		TAPPING SCREW	BTA	Binding Head Tapping Screw(A Type)	
	P	Pan Head Screw			BTB	Binding Head Tapping Screw(B Type)	
	T	Stove Head Screw (Truss)			RTA	Round Head Tapping Screw(A Type)	
	B	Binding Head Screw			RTB	Round Head Tapping Screw(B Type)	
	F	Flat Countersunk Head Screw		SETSCREW	SF	Hex Socket Setscrew(Flat Point)	
	O	Oval Countersunk Head Screw			SC	Hex Socket Setscrew(Cup Point)	
WOOD SCREW	RW	Round Head Wood Screw		SS	Slotted Socket Setscrew(Flat Point)		
	FW	Flat Countersunk Wood Screw		WASHER	E	E-Ring (Retaining Washer)	
	OW	Oval Countersunk Wood Screw			W	Flat Washer (Plain)	
SEMS SCREW	BSA	Binding Head SEMS Screw(A Type)			SW	Lock Washer (Spring)	
	BSB	Binding Head SEMS Screw(B Type)			LWI	Lock Washer (Internal Teeth)	
	BSF	Binding Head SEMS Screw(F Type)			LWE	Lock Washer (External Teeth)	
	PSA	Pan Head SEMS Screw(A Type)		TW	Trim Washer (Countersunk)		
	PSB	Pan Head SEMS Screw(B Type)		NUT	N	Hex Nut	

TEAC CORPORATION

3-7-3 NAKA-CHO MUSASHINO TOKYO PHONE (0422) 53-1111

TEAC CORPORATION OF AMERICA

7733 TELEGRAPH ROAD MONTEBELLO CALIFORNIA 90640 PHONE (213) 726-303

TEAC AUSTRALIA PTY., LTD.

165-167 GLADSTONE STREET SOUTH MELBOURNE VICTORIA 3205 PHONE 69-6000